

**FELIX 26**  
**A PUBLIC DOMAIN DESIGN FOR D.I.Y. BUILDERS OF SMALL CRUISING CATAMARANS.**  
by Bob Willcox [rdwillcox@googlemail.com](mailto:rdwillcox@googlemail.com)

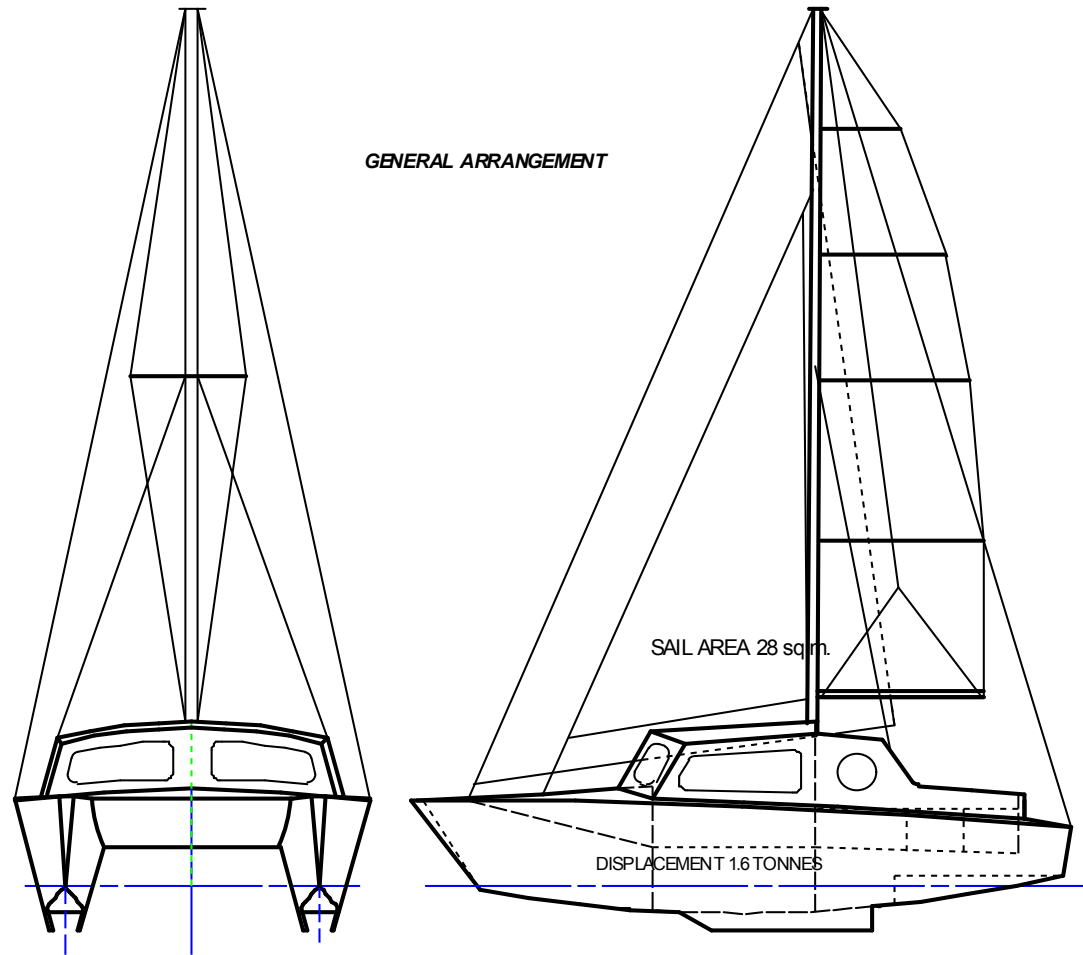

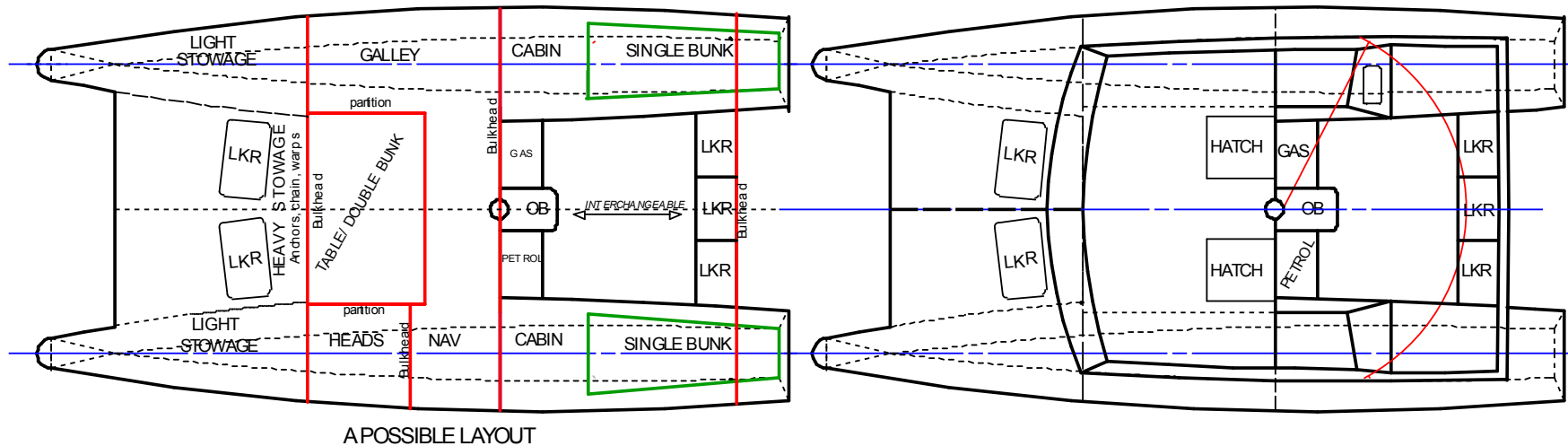

Working drawings start on page 10. The CAD design file can be emailed to users of DeltaCAD ( Google it - US\$40) for developing personal variations. DXF and DWG files also available but quality is poor.

## INTRODUCTION

In 1973 I was 36 years old and crewing in a Halcyon 27, a long keeled monohull. We were running in a F5/6 and our skipper was pushing. The foresail was poled out one side and the mainsail lashed forward on the other. Neither was reefed. We were rolling slowly and rhythmically, the sea splashing everywhere. I was wedged in a pushpit corner in my oilies and feeling a bit sick when I saw an Iroquois cat overtaking us on the same course. It had up a scrap of mainsail, nothing else. The skipper was standing in his cockpit in a dry shirt. He was handed a hot mug of something from below. A hot mug of anything was out of the question for us. The Iroquois was steady, comfortable, safe and dry - and faster! That was my Toad of Toad Hall moment. Poop! Poop!

Since then I've sailed many cats, built some to order using either plywood/epoxy or GRP foam/balsa sandwich, owned four and worked with or talked at length to some of the pioneering designers and/or builders of my generation who were ...

Derek Kelsall when he was based in Kent, England,  
James Wharram in Cornwall, England,  
Chris Hammond at his garden centre nursery?. in S England,  
Tom and Mary Lack at Christchurch, England,  
Peter Spronk when he had a bungalow and a big shed in S England.

I've not met Richard Woods but I admire his designs, he favours lightness and performance. I've seen Kismet Dezines on paper and been impressed, they favour building simplicity and flat bottomed hulls. I've sailed an Iroquois and loved it but thought it too powerful and complex for safe single handing. I've cruised on a Catalac 8m, had fun and was very comfortable but thought it too slow. Hironnelles sail very well and are easy to single hand but are cramped and slam. I've sailed in heavy seas in a Prout Snowgoose and a Heavenly Twins 26 and experienced a lot of slamming.

It is now 2008 and based on my own experiences I have designed the Felix 26, a new small cruising catamaran with a sloop rig. She will sleep 4 adults and cruise at around 7 knots. She will be very simple to build and easy to sail single handed. One person will be able manhandle her without trouble when mooring or pushing off.

The program *Hullform 9.1* was used to develop her hulls. I know she won't be everybody's ideal but she is mine.

#### **REDUCING LEEWAY**

Catamarans remain too influenced by monohull yacht designs which favour roundish hulls because of heeling. Round hulls also have the least wetted area but they're hard to build. In any case monohulls need keels for stability and to reduce leeway and keels increase wetted areas.

Now consider high sided road trucks with square edges at the top. They topple over in strong side winds whereas those with round edges stay upright. It's the drag from vortices along the square edges that pulls them over. Round edges don't produce vortices. For this reason towed caravans with round edges are safer to pull than square edged ones. Square edges in the air are bad.

Conversely square edges in the water can be good. Monohull keels have straight edges creating vortices, adding sideways drag to their lateral resistance. A dory or 'flattie' has a sharp edged hull but if it's a monohull its beam is

wide for stability resulting in a shallow draft which lessens the lateral resistance thereby offsetting the extra drag of the flattie shape. In catamarans narrow hulls are a virtue and instability is not a problem, flattie hulls can be deep. In small catamarans this flatness is insignificant when countering pounding. For large cats the chines are rounded at the bows to avoid pounding and at the sterns to improve flow as the water closes behind the hulls.

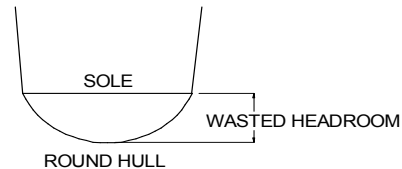
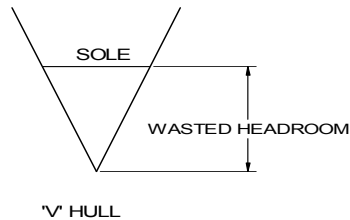

Flatties also need less headroom which means less windage.

## DESIGN POINTS

Felix will be simple and therefore cheap to build using my new, unique 'quick assembly' feature which avoids the tedium of constructing and accurately aligning frames, a preliminary of customary boat construction in which the frames are discarded later when they're needed no longer.

She will be a fast cruiser with plenty of elbow room in the cockpit and below. Every line in her design has a functional reason for being where it is, no styling has been added. Most striking are her flattie hulls, each one with two fixed, low aspect ratio keels to double the area of lateral resistance and the number of vortices yet still have a shallow draft. To keep construction simple these keels are part of the hull side panels. The high bridgedeck lessens slamming in heavy seas – no noisy, juddering halts to scare children and novices, shake the rigging and spoil sleep.

The bows are slim. The soles of the flattie hulls start at a point at the bows under the waterline and widen as they go aft. They stay wide towards the sterns to resist pitching including the rhythmic pitching or 'nodding' that is the nauseous curse of some catamarans, even a few modern ones.

The sterns end above the water line to avoid drag and to offer more buoyancy for extra dampening of pitching in heavy seas. No rudders are shown. My choice would be transom hung kick-ups. The sterns are so angled that when these rudders are fully down they will be semi-balanced, useful when sailing in strong winds under autopilot yet still give feedback when steering manually.

The foredeck has a small trampoline forward letting the solid bridgedeck start as far aft as possible to lessen slamming yet provide anchorage for a forward forestay for ghosters. The foredeck is high for safer crewing and this height is carried aft along the side decks to give safe space below decks above the galley stove. Side decks are lower by the cockpit for easy access when a dinghy is alongside. All decks are cambered. All sidedecks are uncluttered and at least 0.3m wide.

In the cockpit someone 1.67m tall can see over the saloon. The aft cabins shelter the cockpit crew. The cockpit is clear for swift single handing. The mast is on the saloon's aft bulkhead for the same reason, with halyard winches within reach from the cockpit and halyard cleats inside the cockpit. The boom does not obstruct the side decks. There are twin hatches to the saloon so one can either step straight down into the hulls or sit immediately at the saloon table. These hatches, rather than a central hatch-cum-door, also permit simple transfer of mast load to Felix's monocoque structure. The outboard is positioned close to the centre of gravity.

Below decks the saloon has sitting headroom and the hulls have standing headroom. There is a 0.6m wide gangway between the hulls that doesn't intrude on the double bunk space. (Getting to the loo at night is easy.) Single bunks are aft in each hull.

## MODIFICATIONS

The design shown is the basic one. Modifications are always possible with more money, material and work. Extra sail area is feasible, say up to about 33m<sup>2</sup>, more than this may be pointless. For more foot room under the saloon table a pod can be added under the bridgedeck stretching aft to the outboard pod but it may slam in a minor way in heavy seas. A nacelle would be better than a pod but more complex to build. The saloon roof can be raised for more headroom but this means more windage. A cockpit cuddy between the aft cabins is possible but again, more windage. (In bad weather I used to helm sitting in the saloon with my electric autopilot's remote control to hand, stepping out when the need arose knowing my course would be kept.)

Six adults need a displacement of 2.2 tonnes which means slightly wider hulls to maintain bridgedeck height and a slightly wider beam so that these wider hulls don't impinge on the double bunk area. These extra widths will let the single bunks be converted to doubles by peeling strips off the inner hull sides which are then boxed in with matching bridgedeck strips. Doing this also provides earlier steps down into the hulls. Cruising will be a little slower and there will be minor slamming. Of course if one sails only in fair weather then

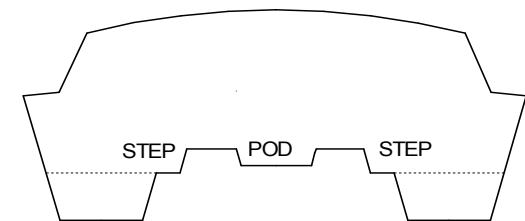

none of these sailing disadvantages apply except the slightly slower speed, but the extra cost and effort of modifying will remain.

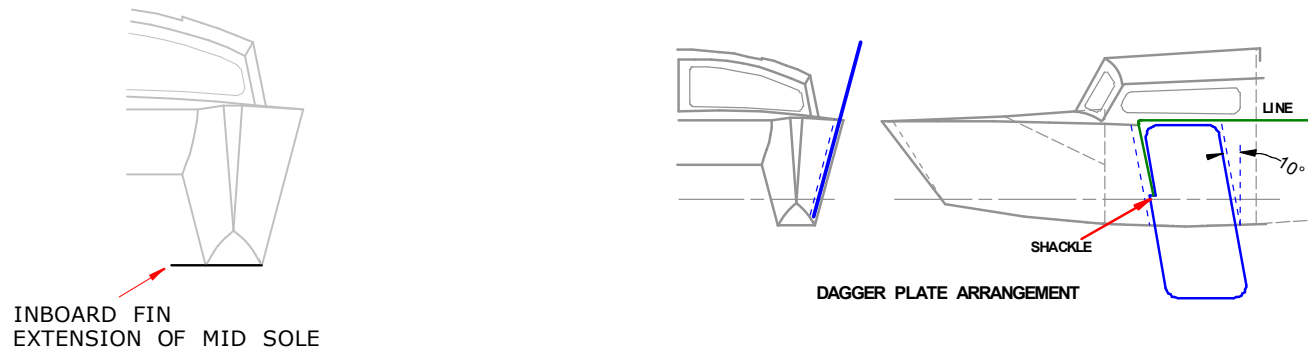

For a draft of 0.33m the keels can be replaced by inboard fins or outboard dagger plates.

## BUILDING A FELIX

### Introduction

In my time I've used three building methods. I've assembled epoxied plywood panels using the WEST stitch and glue system where only simple carpentry skills were required. A lighter catamaran was made using notched plywood bulkheads and frames with glued in stringers to which thinner plywood sheets were glued but higher carpentry skills were needed and it took more time and effort. GRP sandwich with a core of either foam or end grain balsa was another method but it was more laborious, more costly, more time consuming and messier than either of the other two and resulted in catamarans of much the same weight as stitch and glue. This article assumes Felix will be built using stitch & glue.

All Felix's panels are either flat or simple curved surfaces of slight curvature to keep construction easy. All curves are arcs of circles. She has no compound curves. When building her one should concentrate on her hulls being identical, fair and in true alignment. The rest of her need only look right to the eye. The use of epoxy putty as glue means that accurate cutting is not vital provided one tends to under cut rather than over cut. Gaps will be filled later with the

putty. Cured putty is stronger than the panels it's gluing together. DO be generous with epoxy. DON'T use it sparingly.

## MAKING THE KIT

Plywood sheets are cut to shape and clear epoxy coated both sides, resulting in a number of construction panels ready for assembly. Exception – bulkheads but more on this later. The panels are wire stitched and then glued together, stitching sparingly and laying the wire stitches flat ready for hiding in the epoxy putty.

### The Unique Quick Assembly Feature

Each hull has two side panels, an inner and an outer. For quick assembly the inner panels have places for locating bulkheads. When marking out these inner side panels, allow for bulkhead thicknesses.

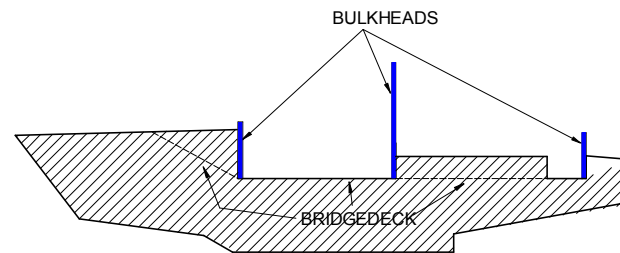

### The Method

Allow epoxy to cure between steps.

Step 1. **Assemble hull panels.** Find a level floor. If it could scratch the epoxied panels put down hardboard sheets. Lay each hull's sides flat on the floor in pairs, inners on top of outers with stubby keels in line. Stitch and glue in the transoms and bow panels, ensuring the panels stay in line with each other whilst the epoxy cures.

Step 2. **Fit hull soles.** With the hulls still on their sides, use spare timber to hold open the sides and entice in the soles. Then stitch and glue them in place. More timber can be used to prop up the panels to give room for working underneath. Stitch along the soles in opposing pairs so that they are drawn gradually to their curved shapes. Be generous with the epoxy fillets around the keels.

Step 3. **Cut bulkheads** from either lightweight industrial foam sandwich laminated sheets or plywood allowing for thicknesses of the other panels. Mark out but do not cut out yet the gangway openings. Glue stringers onto each bulkhead as specified for locating the inner hull side panels and for supporting deck panels. If using plywood epoxy both sides omitting the gangway areas.

Step 4. **Insert bulkheads**. Stand the hulls upright and level on their twin keels. (They'll look too narrow.) Align them approximately. Offer up the bulkheads. Pull open the inner hull sides until they're caught by all the bulkheads' stringers and finalise the locating of bulkheads. The hulls will now have spread to their designed shapes and be more accurately aligned. Having checked the accuracy of the hull alignments and that the bulkheads are vertical then glue in the bulkheads - stitching may be unnecessary. You will now have your first glimpse of Felix's final shape.  
*WARNING: misalignments will be extremely difficult to correct after gluing.*

Step 5. **Glue inside the hulls**. Complete all epoxy fillets inside the hulls.

Step 6. **Inspect so far**. Inspect all joins made so far, ensuring all epoxy fillets are very generous and with large radii wherever possible to avoid undue stress concentrations.

Step 7. **Fit bridgedeck**. Position bridgedeck panels with props and glue them in.

Step 8. **Cut out gangways** in the bulkheads. If foam sandwich laminated sheets, gouge out the core around the openings and fill with resin putty. If plywood, epoxy the cut edges.

Step 9. **Start fitting out**. Lockers, bunks, seating, etc, are all glued or screwed into place.

Step 10. **Fit decks**. Glue in all decks.

Step 11. **Fit saloon sides**. Fit and glue saloon-cum-cockpit side panels.

Step 12. **Fit saloon roof**. Place saloon roof in position. Offer up the partitions between hulls and saloon and check they do quite reach the roof and that the roof will be a fair curve. Adjust as necessary. Glue partitions into position but NOT to roof. Glue the saloon roof first to saloon side panels, then to main bulkhead and finally to the partitions. Glue in the heads bulkhead.

Step 13. **Fit saloon front**. Stitch & glue saloon front panels

Step 14. **Fit aft cabins**. Glue in aft cabin panels.

Step 16. **Fit out cockpit**. Fit out the cockpit including the outboard well and cover.



**Shape bows.** At any point after Step 4, make foam shapes to round off the bow panels and stick them on.  
*Suggestion* - use a plastic drain pipe of slightly larger diameter than the top of the bows and longer than the bow heights. Lightly grease it inside and expand foam in it. After the foam has set, cut off the excess foam at each end and push out the 'plug'. Slice this plug diagonally along its length to give two bow shapes which are then glued into place. Then wash the foam shapes with detergent to get rid of the grease, fair them in with coarse sandpaper etc and smear them with resin fillers. Give them a fine fairing ready for sheathing.

**Stiffening.** If any additional stiffening is required either glue in hardwood stringers or expand foam in confined spaces.

**Sheathing.** Finally, locally sheath parts of the hulls that may have to take knocks or abrasions, e.g., bows, keels, places where warps or fenders may rub, etc. Then completely sheath the hulls all over, perhaps also the undersides of the bridgedeck. Sheath with clear or coloured epoxy and lightweight woven glass or polyester cloth.

**Protect keels.** If you expect frequent grounding or beaching consider doubling keel thicknesses and protecting them with stainless steel shoes. All of this may be best done with the hulls upside down *before* standing them on their keels for bulkhead fitting (Step 4).

**AND NOW FOR SOME WORKING DRAWINGS...**

## SOME PRELIMINARY NOTES

The following panels make no allowances for material thicknesses.

I suggest use douglas fir plywood WBP throughout. Marine ply is also OK but expensive.

For soles, decks and saloon roof suggest 9mm thick ply. For hull and saloon sides 6mm ply.

For bulkheads, bows and sterns, 25mm ply.

# HULL SIDES

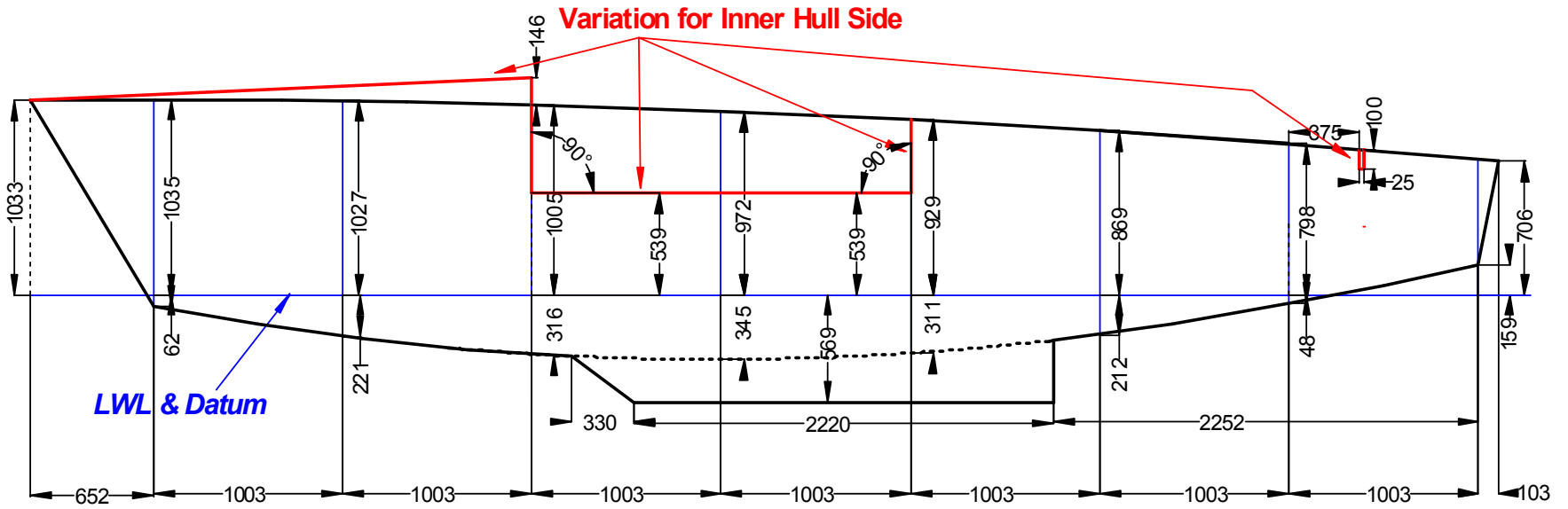

# HULL SOLE, BOW & STERN

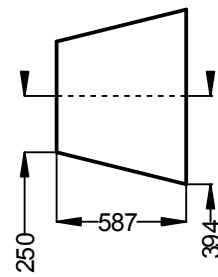
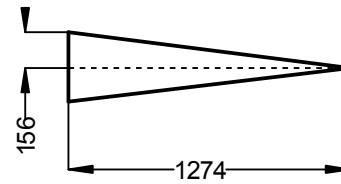
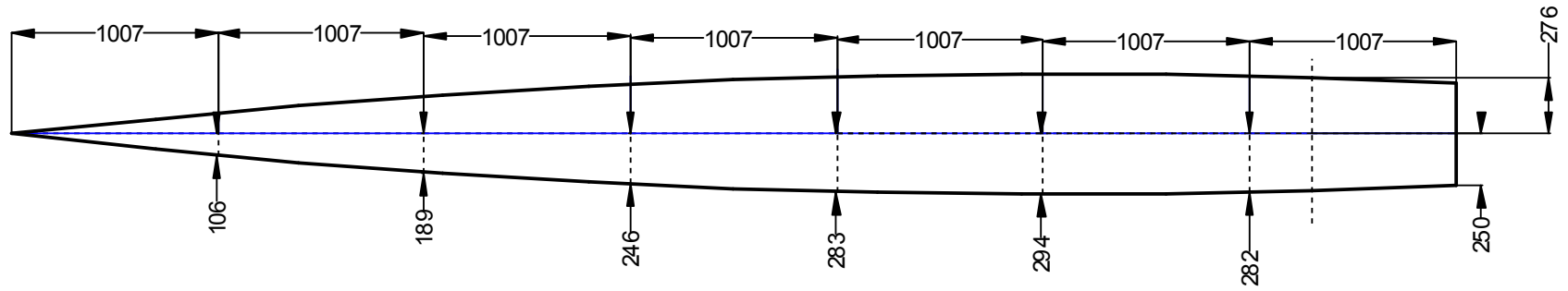

# MAIN BULKHEAD

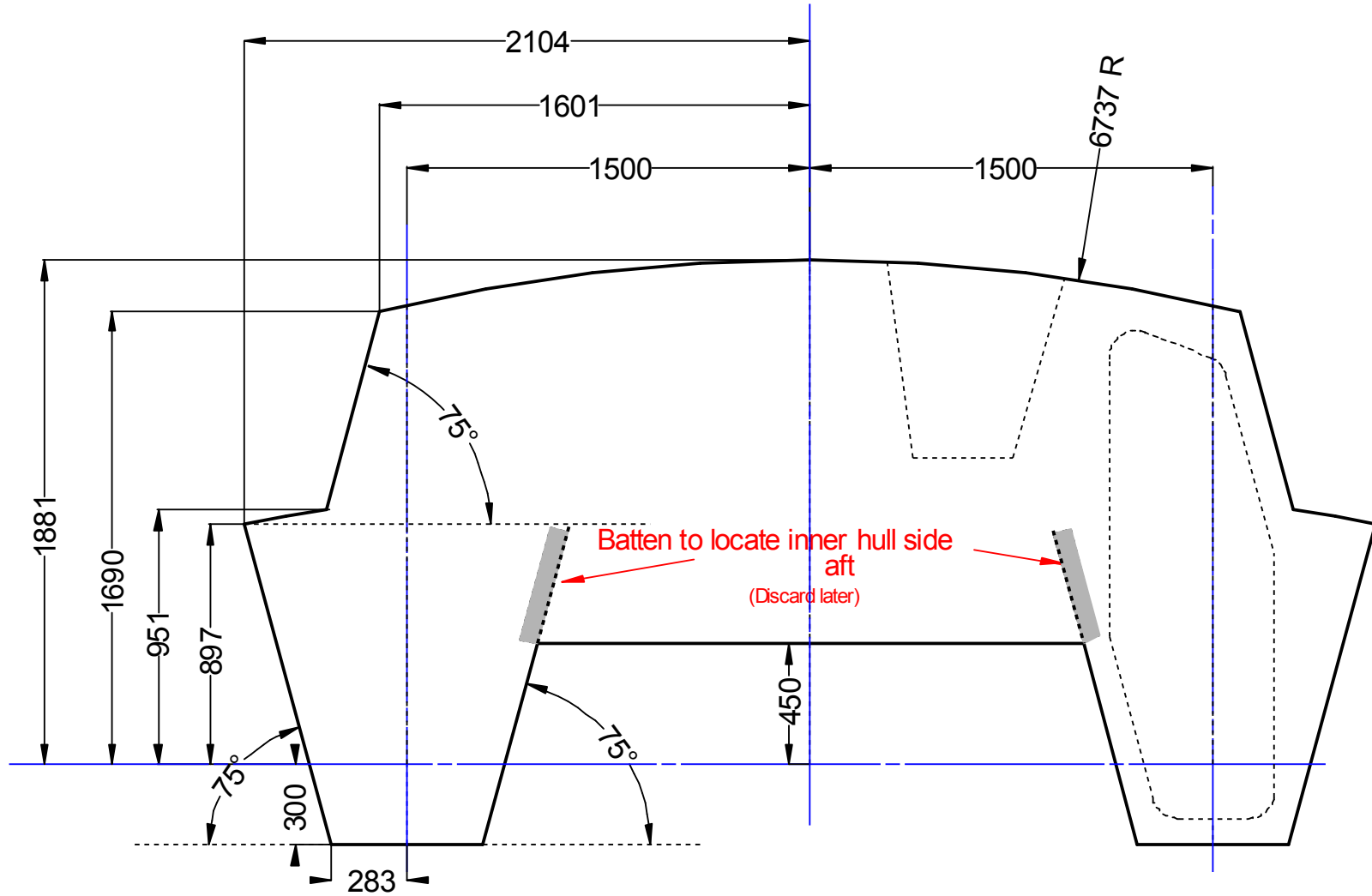

# FORWARD BULKHEAD

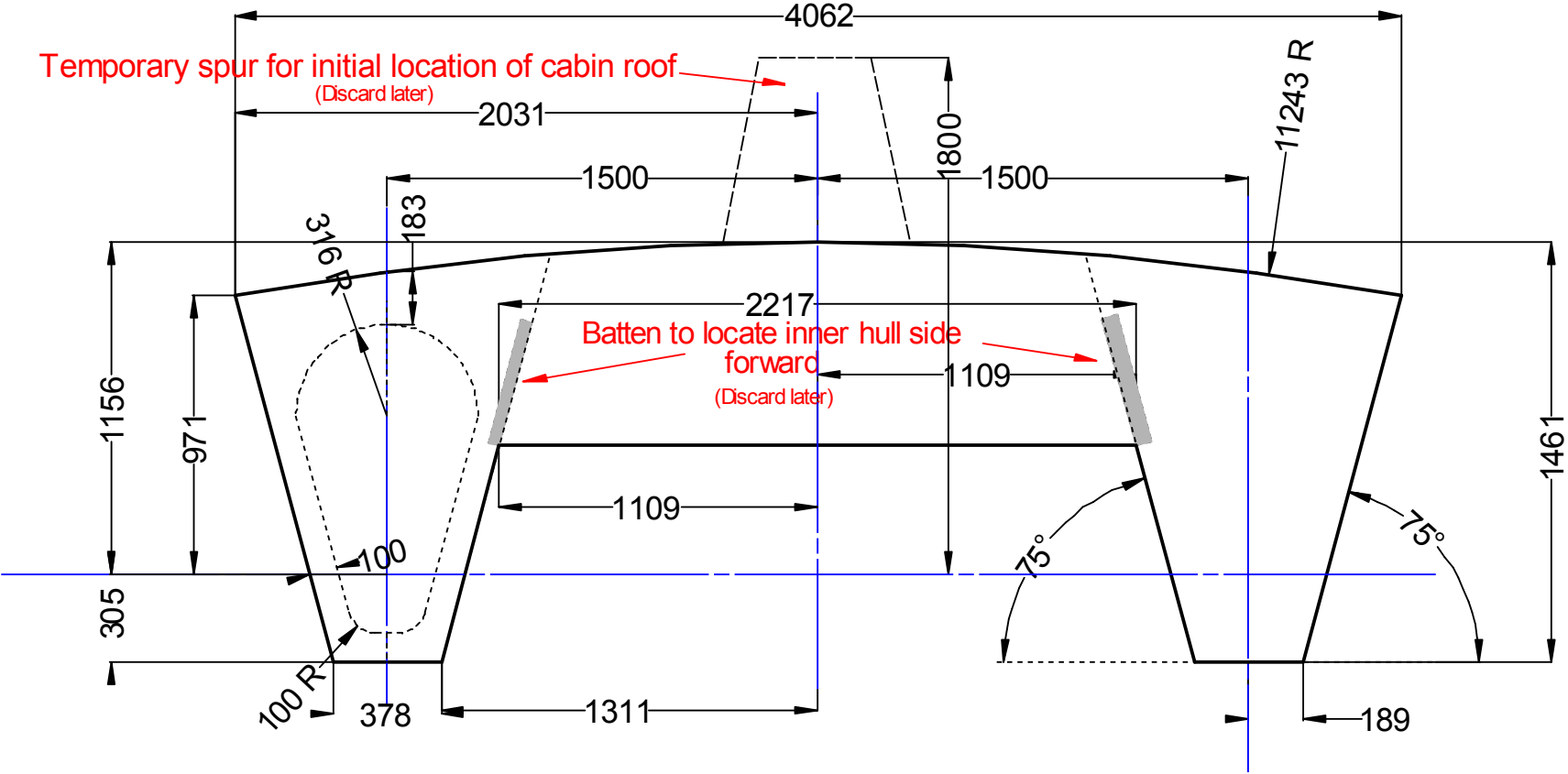

# AFT BULKHEAD

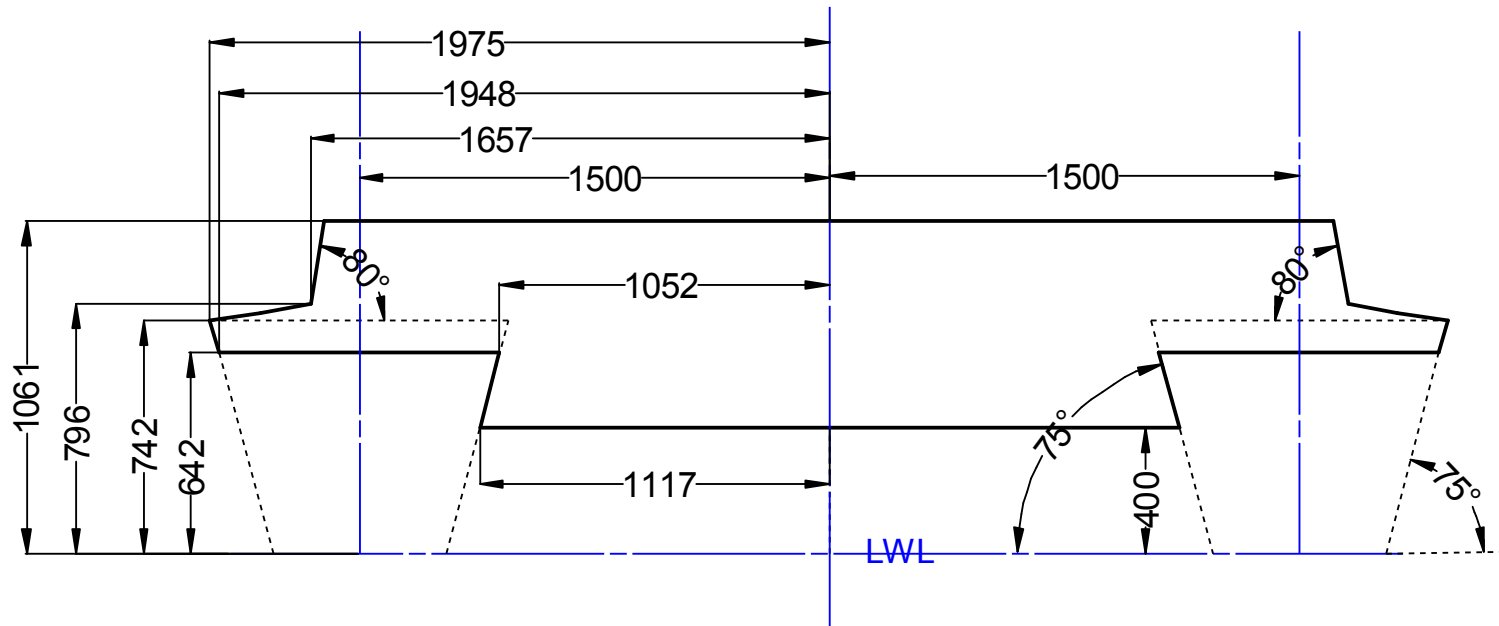

# CABIN & COCKPIT SIDE PANEL

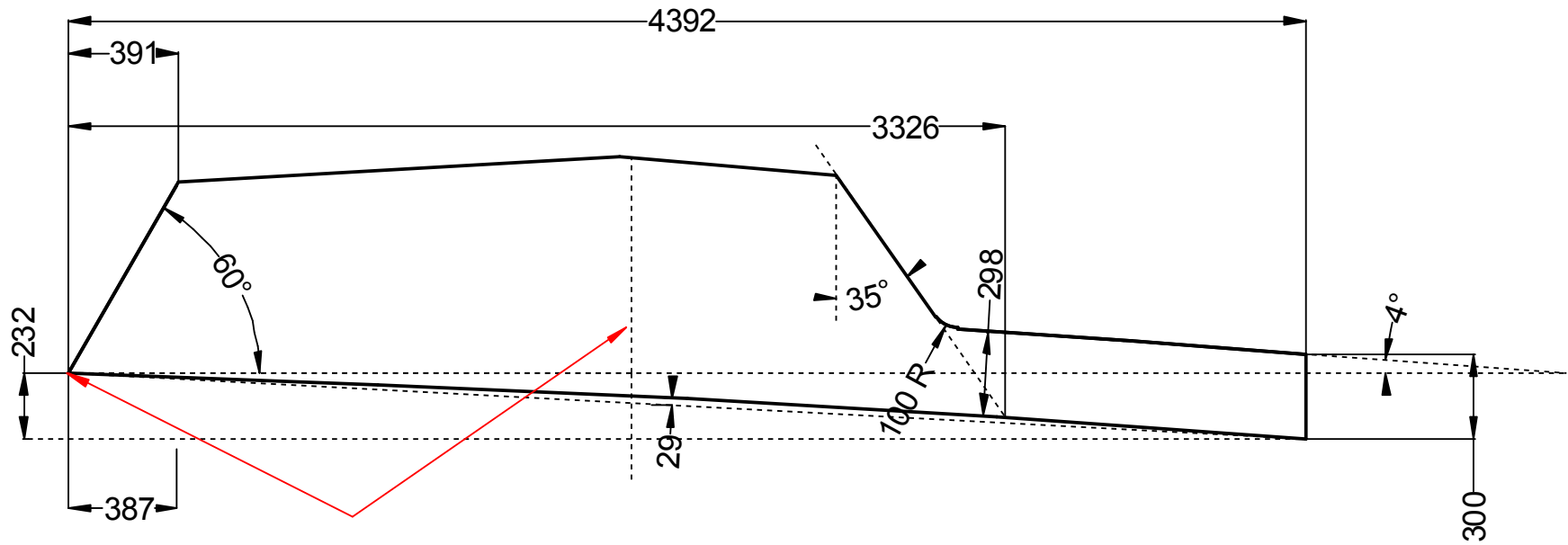



# FOREDECK

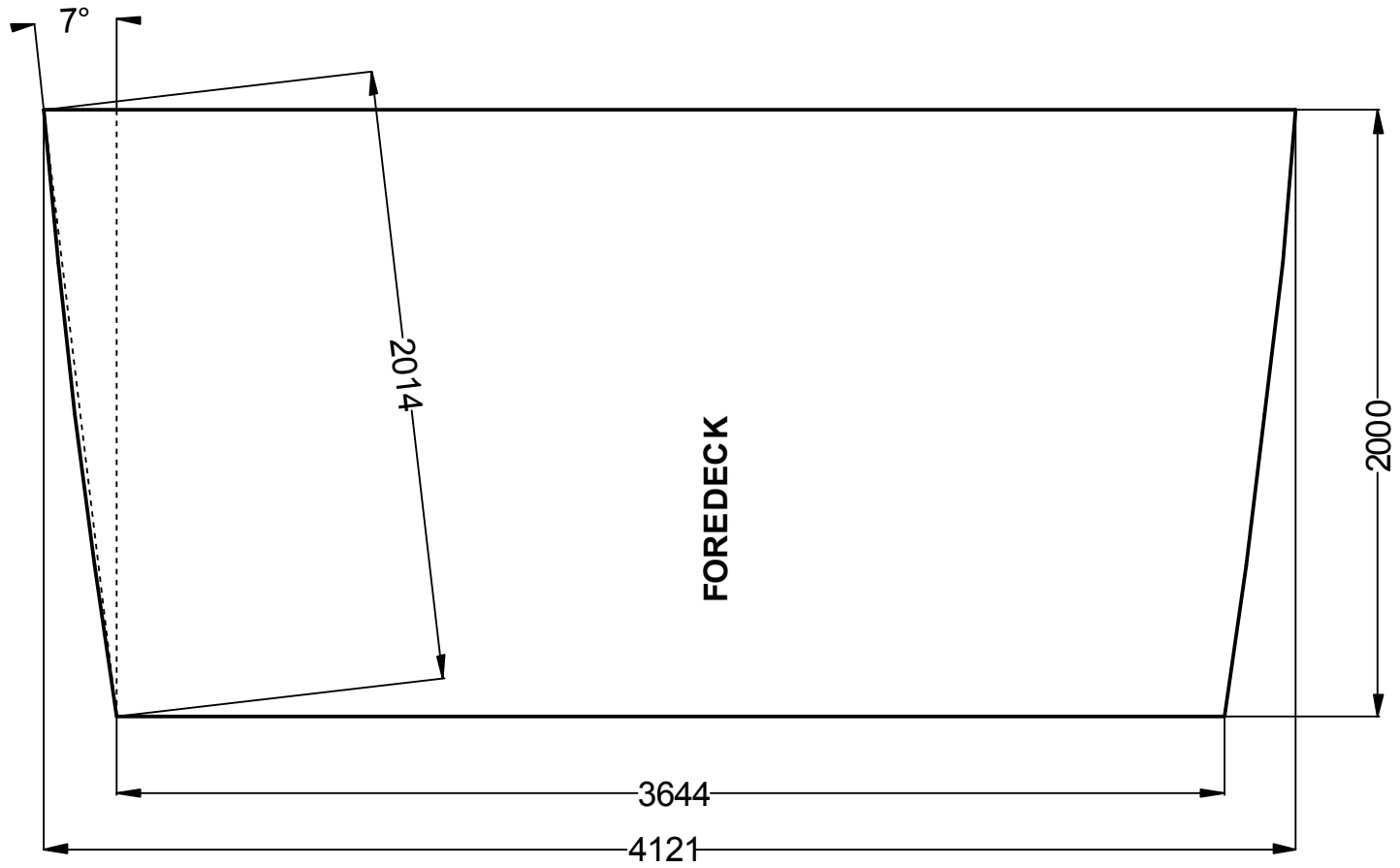

# SALOON ROOF

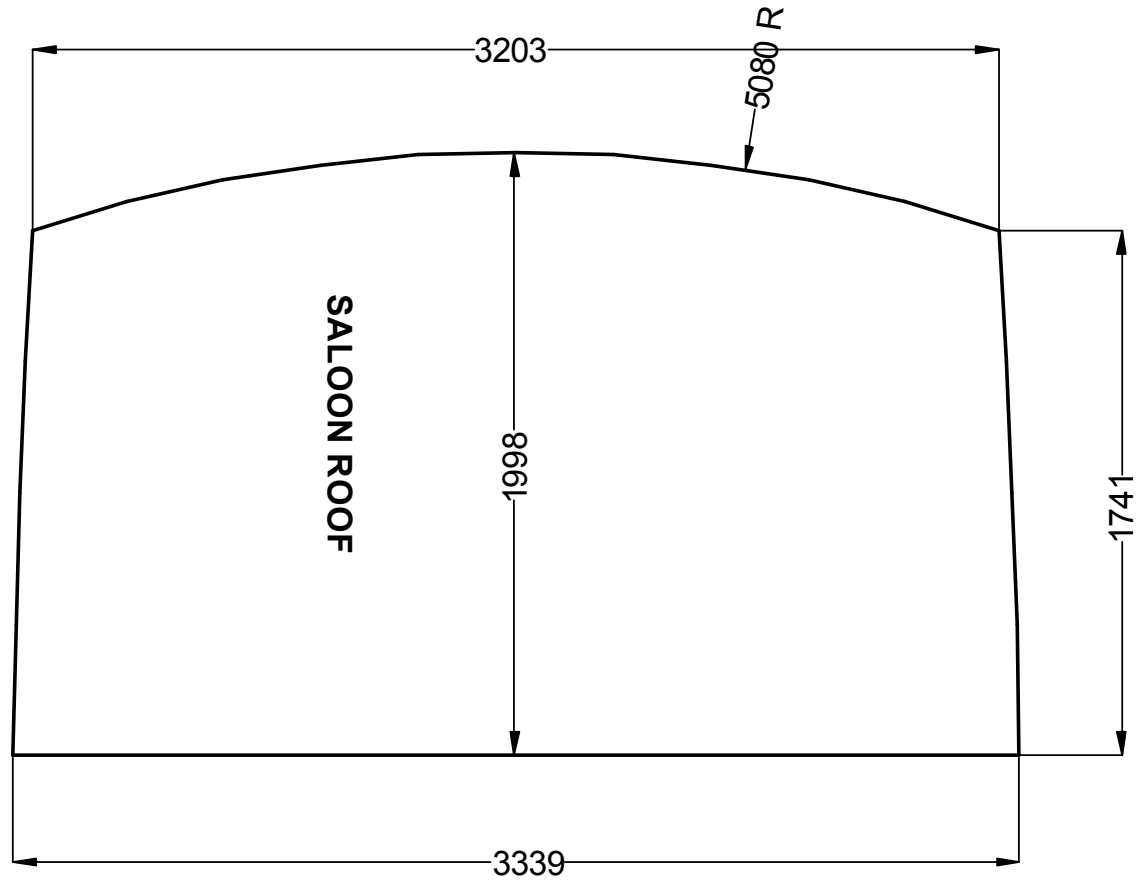

# OTHER DECK PANELS

