

FELIX 26

A PUBLIC DOMAIN DESIGN FOR D.I.Y. BUILDERS OF SMALL CRUISING CATAMARANS by Bob Willcox rdwillcox@gmail.com
WITH UNIQUE QUICK ASSEMBLY FEATURE

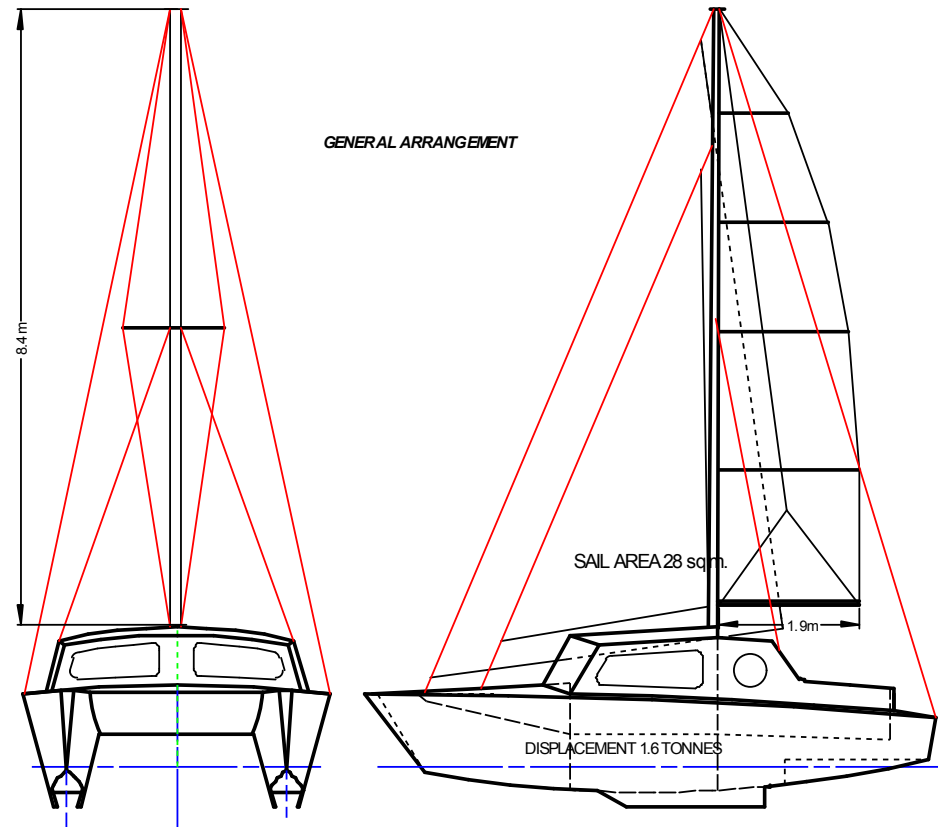

To be built at builder's own risk.

The CAD design file can be emailed to users of DeltaCAD (Google it - US\$40) so they can develop their own variations. DXF and DWG files also available but definition is not 100%.

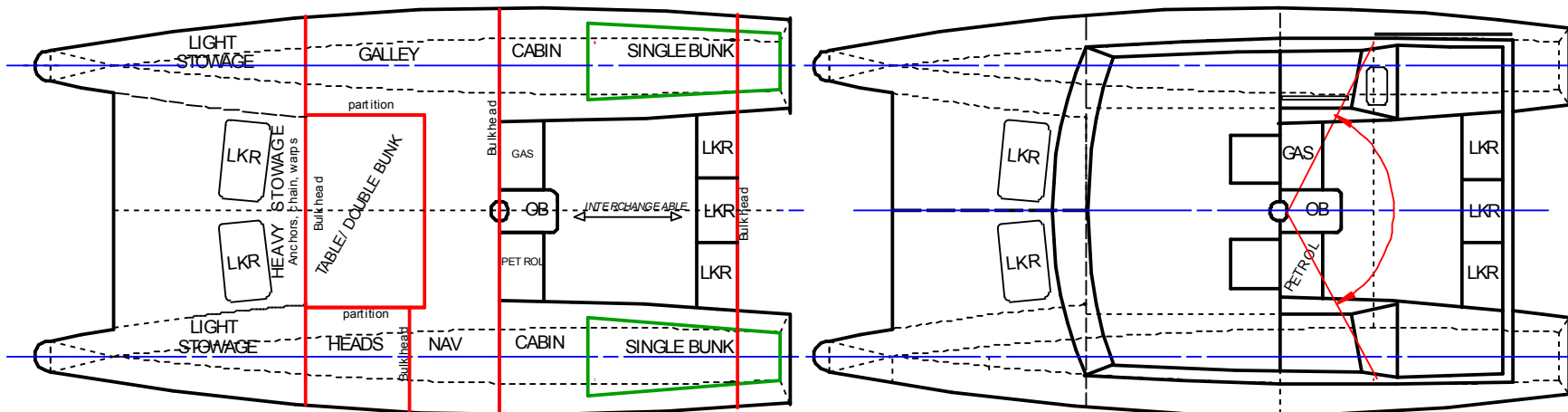

A POSSIBLE LAYOUT

CONTENTS

DESIGN POINTS	Page 3
RIG	Page 3
SOME POSSIBLE MODIFICATIONS	Page 4
CONSTRUCTION SEQUENCE	Page 6
PLANS	Page 9
BACKGROUND & PHILOSOPHY	Page 26

DESIGN POINTS

Felix has a unique 'quick assembly' feature which avoids the tedium of constructing and accurately aligning frames, a preliminary of customary boat construction where the frames are discarded later after they're no longer needed.

Each hull is made from two side panels, an inner and an outer (also from bow, stern and sole panels). The hull panels are assembled on their sides on the floor. Afterwards they are stood on their keels. The bulkheads are then introduced located by the inner hull panels. *Easy! Simple! Quick!*

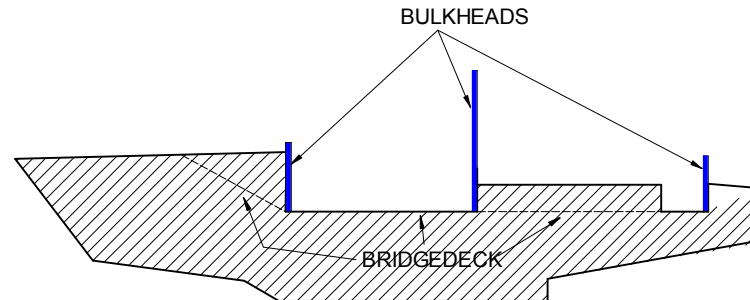

Felix will be a fastish cruiser with good elbow room in the cockpit and below. Every line in her design has a functional reason for being where it is, no styling has been added. Most striking are her flattie hulls, each one with two fixed, low aspect ratio keels to double the area of lateral resistance and the number of vortices yet still have a shallow draft. To keep construction simple these keels are part of the hull side panels. The high bridgedeck lessens slamming in heavy seas – no noisy, juddering halts to scare children and novices, to shake the rigging and to spoil sleep.

The bows are slim. The soles of the flattie hulls start at a point at the bows under the waterline and widen as they go aft. They stay wide towards the sterns to resist pitching including the rhythmic pitching or 'nodding' that is the nauseous curse of some catamarans, even a few modern ones.

The sterns end above the water line to avoid drag and to offer more buoyancy for extra dampening of pitching in heavy seas. No rudders are shown. My choice would be transom hung kick-ups. The sterns are so angled that when these rudders are fully down they will be semi-balanced, useful when sailing in strong winds under autopilot yet still give feedback when steering manually.

The foredeck is solid and provides anchorage for a forward forestay for ghosters. It is high for safer crewing and this height is carried aft along the side decks to give space below decks above a galley stove. Side decks are lower by the cockpit for easy access when a dinghy is alongside. All decks are cambered. All sidedecks are 0.3m wide.

In the cockpit someone 1.67m (5ft 6in) tall can see over the saloon. The aft cabins shelter the cockpit crew. The cockpit is clear for swift single handing. The mast is on the saloon's aft bulkhead for the same reason, with halyard winches within reach from the cockpit and halyard

cleats inside the cockpit. The boom does not obstruct the side decks. There are twin hatches to the saloon so one can either step straight down into the hulls or sit immediately at the saloon table. These hatches, rather than a central hatch-cum-door, also permit simple transfer of mast load to Felix's monocoque structure. The outboard can be positioned close to the centre of gravity.

Below decks the saloon has sitting headroom and the hulls have standing headroom. There is a 0.6m wide gangway between the hulls that doesn't intrude on the double bunk space. (Getting to the loo at night is easy.) Single bunks are aft in each hull.

RIG

Rig is a personal thing. I suggest a mast about 8.4m high and a boom about 1.9m long. A high mast allows large ghosters and spinnakers to be set in light winds. One can always reef for strong winds but one cannot add mast height in light winds. A short boom keeps the side decks clear for easy and safe crew movement.

POSSIBLE MODIFICATIONS

The design shown is the basic one. Modifications are always possible with more money, material and effort. Extra sail area is feasible, say up to about 33m², more than this may be pointless. For more foot room under the saloon table a pod can be added under the bridgedeck stretching aft to the outboard pod but it may slam in a minor way in heavy seas. A nacelle would be better than a pod but more complex to build. The saloon roof can be raised for more headroom but this means more windage. A cockpit cuddy between the aft cabins is possible but again, more windage. (In bad weather I used to helm sitting in the saloon with my electric autopilot's remote control to hand, stepping out when the need arose knowing my course would be kept.)

Six adults rather than four will need a displacement of 2.2 tonnes which means slightly wider hulls to maintain bridgedeck height and a slightly wider beam so that these wider hulls don't impinge on the double bunk area. These extra widths will let the single bunks be converted to doubles by peeling strips off the inner hull sides which are then boxed in with matching bridgedeck strips. Doing this also provides earlier steps down into the hulls. Cruising will be a little slower and there will be minor slamming. Of course if one sails only in fair weather then none of these sailing disadvantages apply except the slightly slower speed, but the extra cost and effort of modifying will remain.

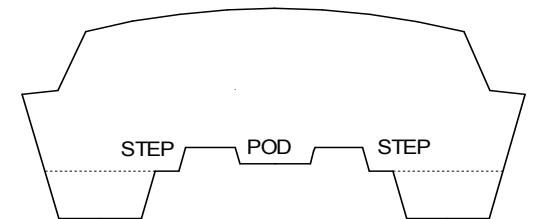

For an even shallower draft ...

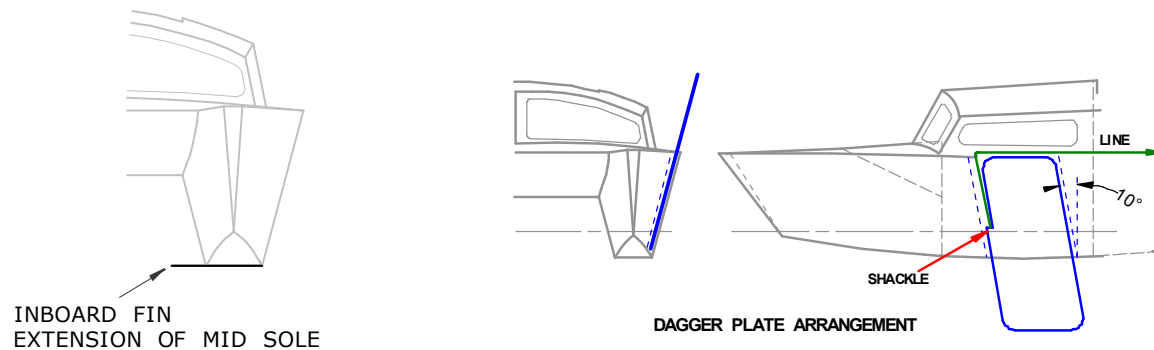

BUILDING NOTES

Introduction

In my time I've used three building methods. I've assembled epoxied plywood panels using the WEST stitch and glue system where only simple carpentry skills were required. A lighter catamaran was made using notched plywood bulkheads and frames with glued in stringers to which thinner plywood sheets were glued but higher carpentry skills were needed and it took more time and effort. GRP sandwich with a core of either foam or end grain balsa was another method but it was more laborious, more costly, more time consuming and messier than either of the other two and resulted in catamarans of the same weight as stitch and glue. Felix is designed for stitch & glue plywood.

All Felix's panels are either flat or simple curved surfaces of slight curvature to keep construction easy. All curves are arcs of circles. She has no compound curves. When building her one should concentrate on her hulls being identical, fair and in true alignment. The rest of her need only look right to the eye. The use of epoxy putty as glue means that accurate cutting is not vital provided one tends to under rather than over cut as gaps will be filled later with epoxy putty. Cured putty is stronger than the panels it's gluing together.

Boat building using this technique is akin to sculpting. It's not precision engineering. The basic boat shape is provided by the assembled panels and the epoxy putty is the sculpting material which gives the boat its final faired shape and beauty at the edges where the panels are joined. Do as much fairing as possible whilst the putty is 'wet'. Once the putty is cured final fairing by hand is strenuous even with sanding and grinding machines.

DO be generous with epoxy and its putty. DON'T use them sparingly.

As the plywood will be epoxy coated, its surfaces should not be smooth for effective keying of the epoxy. Ply with a smooth veneer obtained

as a bargain should be deliberately 'distressed' with coarse sand paper or scratched with a pad of nails.

The plywood sheets are cut to shape. The resulting panels should be dried in a small heated space. Only omit drying if relative humidity has been and is sure to be below 15% for long periods. After drying the cut panels are laid flat and clear epoxy coated both sides, first one side and after it has cured (up to 24 hours), then the other. Whilst the first side cures keep the other side flat on the floor or other surface to exclude air. Epoxy coating has to be fairly quick as wood notoriously readily attracts moisture from the air. Use a plastic spreader to 'float' an epoxy coat on a side making sure there are no thin patches whatsoever. (Brushing on epoxy tends to give thin patches.) Plan for easy batch production to ensure all ply is dry when coated. Eventually you will have a number of panels ready for assembly. They will be wire stitched and then glued together with epoxy putty, stitching sparingly and laying the wire stitches flat ready for hiding in the putty.

TECHNIQUES

This youtube video is helpful and links to many other videos...

<http://www.youtube.com/watch?v=KUglZwwu2CA>

CONSTRUCTION SEQUENCE

Allow epoxy to cure between steps.

Step 1. **Assemble hull panels.** Find a level floor. If it could scratch the epoxied panels put down hardboard sheets. Lay each hull's sides flat on the floor in pairs, inners on top of outers with stubby keels in line. Stitch and glue in the stern and bow panels, ensuring the hull panels stay in line with each other whilst the epoxy cures.

Step 2. **Fit hull soles.** With the hulls still on their sides, use spare timber to hold open the sides and entice in the soles. Then stitch and glue them in place. More timber can be used to prop up the panels to give room for working underneath. Stitch along the soles in opposing pairs so that they are drawn gradually to their curved shapes. Be generous with the epoxy fillets around the keels.

Step 3. **Cut bulkheads** from plywood allowing for thicknesses of the hull panels. Mark out but do not cut out yet the gangway openings. Glue stringers onto each bulkhead as specified for locating the inner hull side panels and for supporting deck panels. Epoxy both sides omitting the gangway areas.

Step 4. **Insert bulkheads.** Stand the hulls upright and level on their twin keels. (They'll look too narrow.) Align them approximately. Offer up the bulkheads and entice them in. Pull open the inner hull sides until they're caught by all the bulkheads' temporary battens. Finalise the locating of bulkheads. The hulls will now have spread to their designed shapes and be more accurately aligned. Having checked the accuracy of the hull alignments and that the bulkheads are vertical then glue in the bulkheads - stitching may be unnecessary. You will now have your

first glimpse of Felix's final shape. **WARNING: misalignments will be extremely difficult to correct after gluing.**

Step 5. **Glue inside the hulls.** Complete all epoxy fillets inside the hulls.

Step 6. **Inspect so far.** Inspect all joins made so far, ensuring all epoxy fillets are very generous and with large radii wherever possible to avoid undue stress concentrations. Modify as necessary.

Step 7. **Fit bridgedeck.** Position bridgedeck panels with props and glue them in.

Step 8. **Cut out gangways** in the bulkheads. Epoxy the cut edges.

Step 9. **Start fitting out** while access is easy. Internal lockers, bunks, seating, etc, are all glued or screwed into place.

Step 10. **Fit decks.** Glue in all decks.

Step 11. **Fit saloon sides.** Fit and glue saloon-cum-cockpit side panels.

Step 12. **Fit saloon roof.** Place saloon roof in position. It will need weighing down to achieve its curvature. Offer up the partitions between hulls and saloon and check they do quite reach the roof and that the roof will be a fair curve. Adjust as necessary. Glue partitions into position but NOT to roof. Glue the saloon roof first to saloon side panels, then to main bulkhead and finally to the partitions. Glue in the heads bulkhead.

Step 13. **Fit saloon front.** Stitch & glue saloon front panel.

Step 14. **Fit aft cabins.** Glue in aft cabin panels.

Step 16. **Fit out cockpit.** Fit out the cockpit including the outboard well and cover.

Shape bows. At any point after Step 4, make foam shapes to round off the bow panels and stick them on. *Suggestion* - use a plastic drain pipe of slightly larger diameter than the top of the bows and longer than the bow heights. Lightly grease it inside and expand foam in it. After the foam has set, cut off the excess foam at each end and push out the 'plug'. Slice this plug diagonally along its length to give two bow shapes which are then glued into place. After the glue has set, wash the foam shapes with detergent to get rid of the grease, fair them in with coarse sandpaper etc and smear them with resin fillers. Give them a fine fairing ready for sheathing.

Stiffening. If any additional stiffening is required after construction, either glue in hardwood stringers or expand foam in confined spaces. Check for deck stiffness and, after launch, for any hull panels bulging inwards.

Sheathing. Finally, locally sheath parts of the hulls that may have to take knocks or abrasions, e.g., bows, keels, places where warps or fenders may rub, etc. Then completely sheath the hulls all over, perhaps also the undersides of the bridgedeck. Sheath with clear or coloured epoxy and lightweight woven glass or polyester cloth.

Protect keels. If you expect frequent grounding or beaching consider doubling keel thicknesses and protecting them with stainless steel shoes. This may be best done with the hulls upside down *before* standing them on their keels for bulkhead fitting (Step 4).

EXTRA NOTES...

Dimensions are in millimetres [mm].

Panel dimensions make no allowances whatsoever for material thicknesses.

I suggest use douglas fir plywood WBP throughout. Marine ply is obviously OK but it is expensive and usually *too smooth*.

For soles, decks and saloon roof suggest 9mm thick ply. For hull and saloon sides 6mm ply. For bulkheads, bows and sterns, 12mm ply. Use thinner ply if you wish so long as you watch for flexing after launching and correct it with extra stringers or internal furniture or expanded foam in confined spaces.

You will be building a prototype. As with all prototypes you will come across a few errors as you go along. These can be caused by your own mistakes in previous construction steps or in the reading and translating of drawings, or by my mistakes at the design stage. Be prepared for these mistakes.

Apart from one catamaran, all my builds in the past were prototypes and I always hit mistakes. Before building the second prototype I built a scale model using thin balsa wood sheets, a practice I continued for subsequent prototypes. If nothing else the act of building a model cleared my mind on how construction should proceed. I found 1/20th scale was OK. I suggest you do the same at whatever scale suits you.

It will all probably take a lot longer to complete than you first thought.

Start collecting clean, empty 4 pint plastic milk bottles with their screw tops still in place. Slice off a narrow side to leave you with a very useful open container with a handle underneath, suitable for holding and pouring catalysed epoxy liquid when applying same. You'll get through a lot of these containers as they're thrown away when no longer useable.

THE PLANS

SIDE VIEW
showing clearances

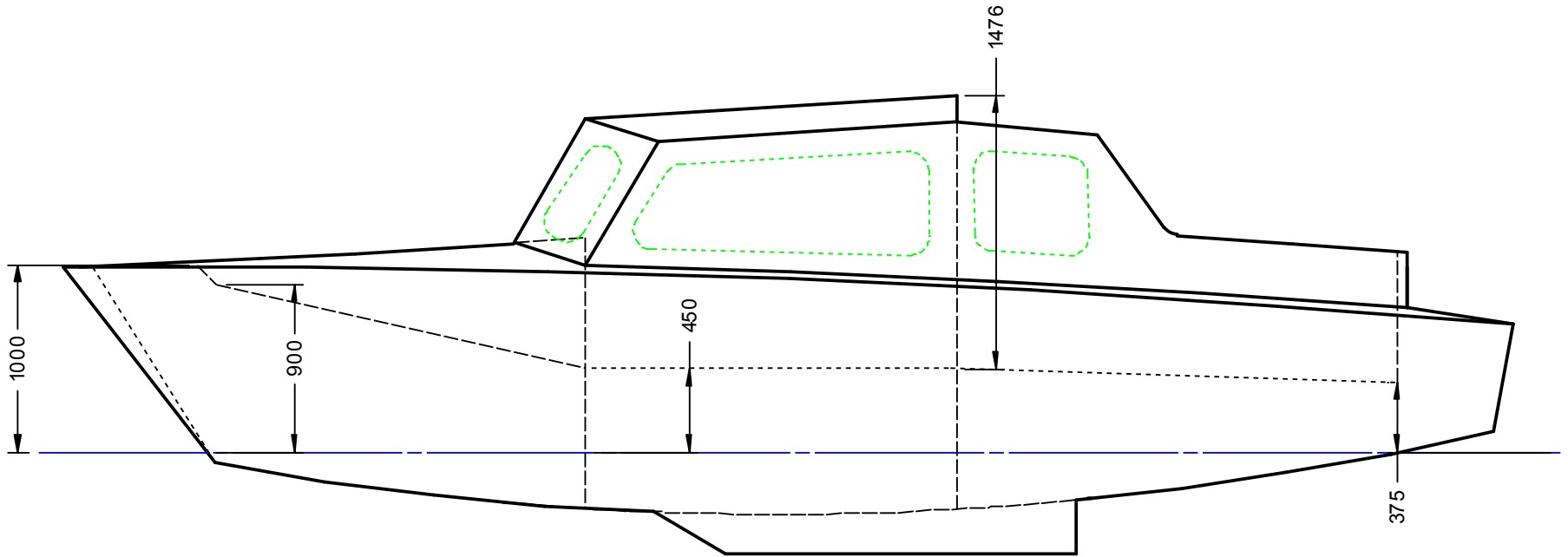

TOP VIEW

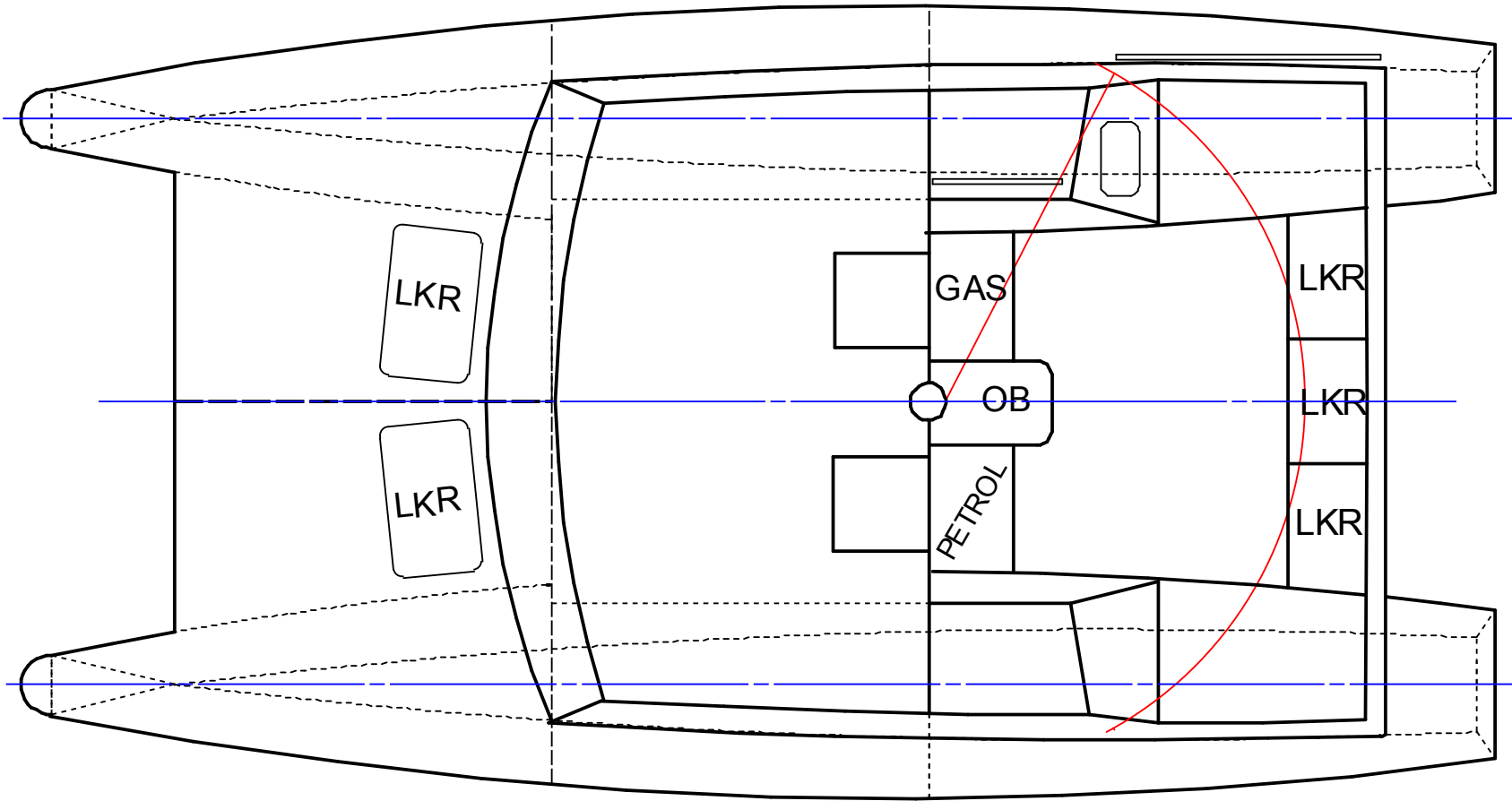

FRONT VIEW

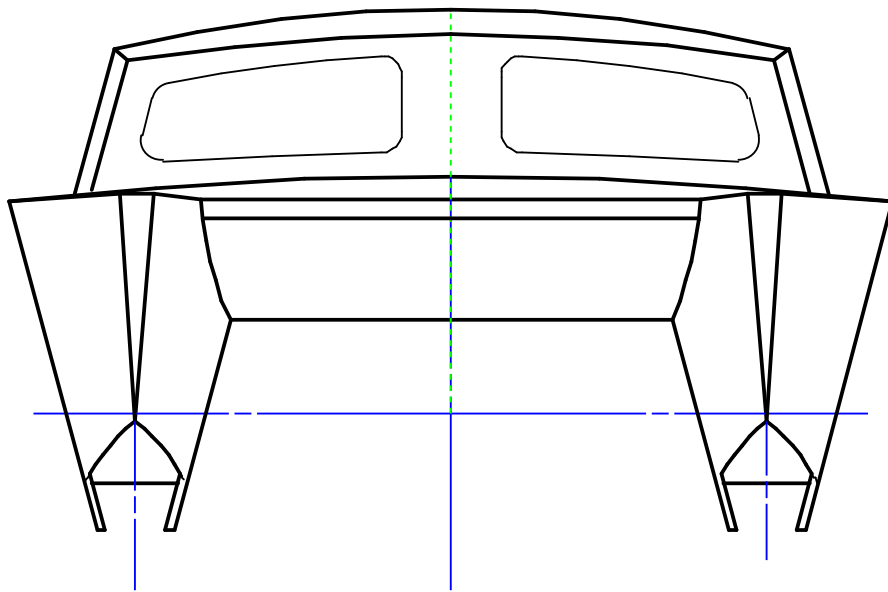

HULL SIDE PANELS

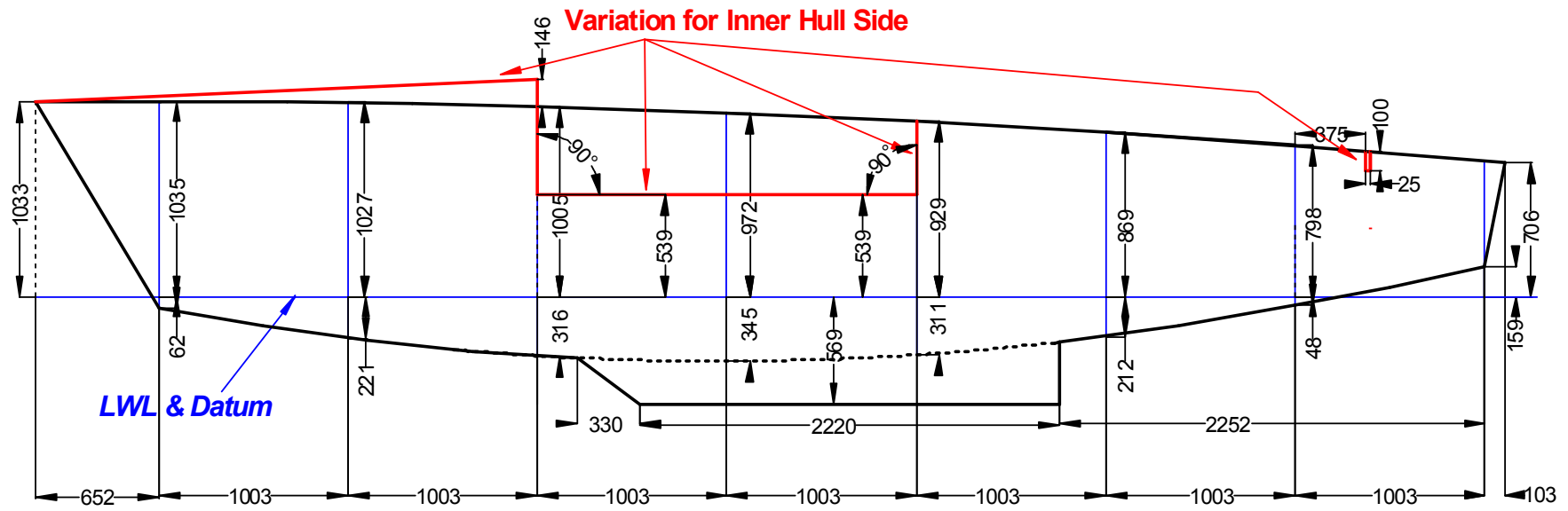

HULL SOLE, BOW & STERN PANELS

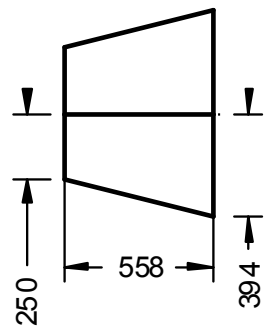
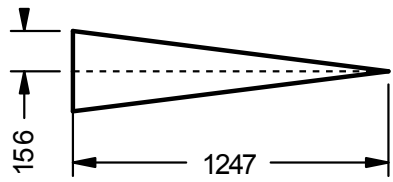
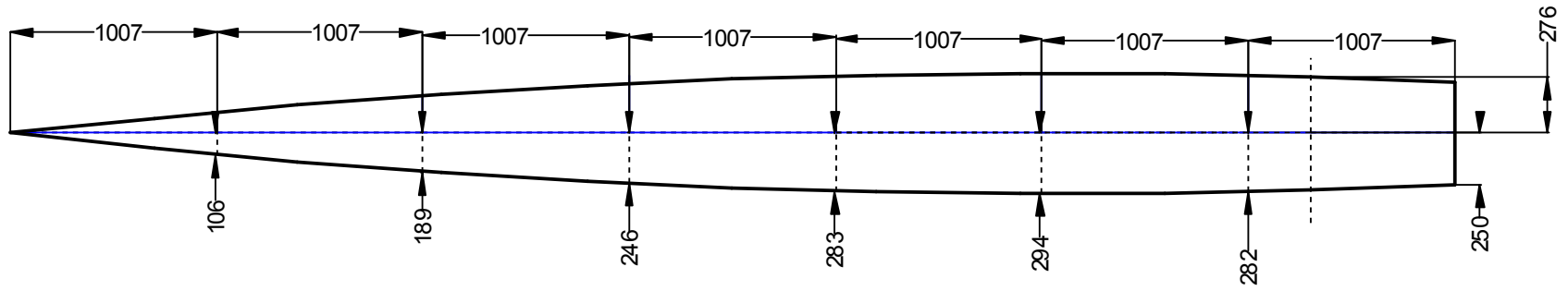

MAIN BULKHEAD PANEL

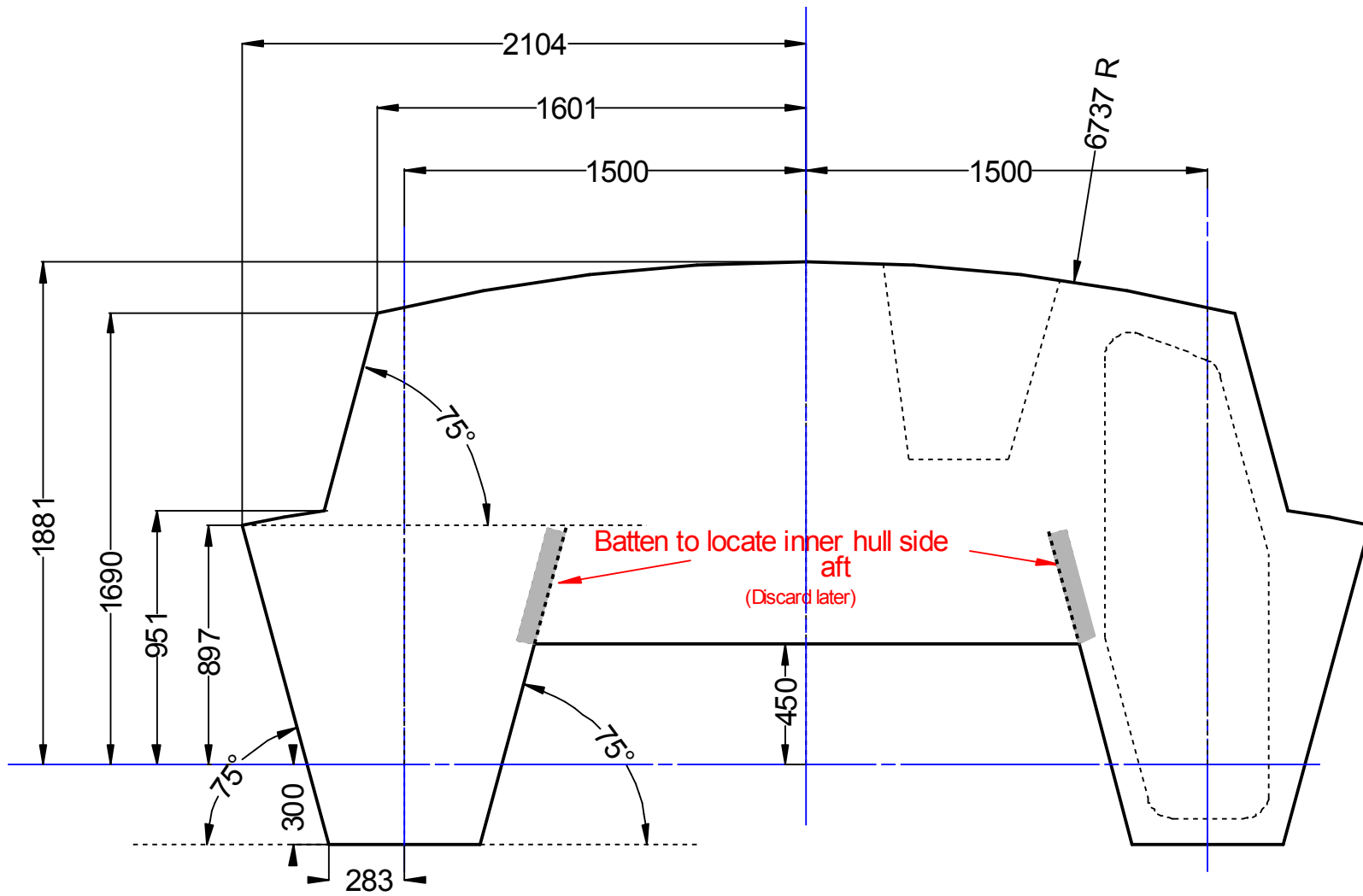

FORWARD BULKHEAD PANEL

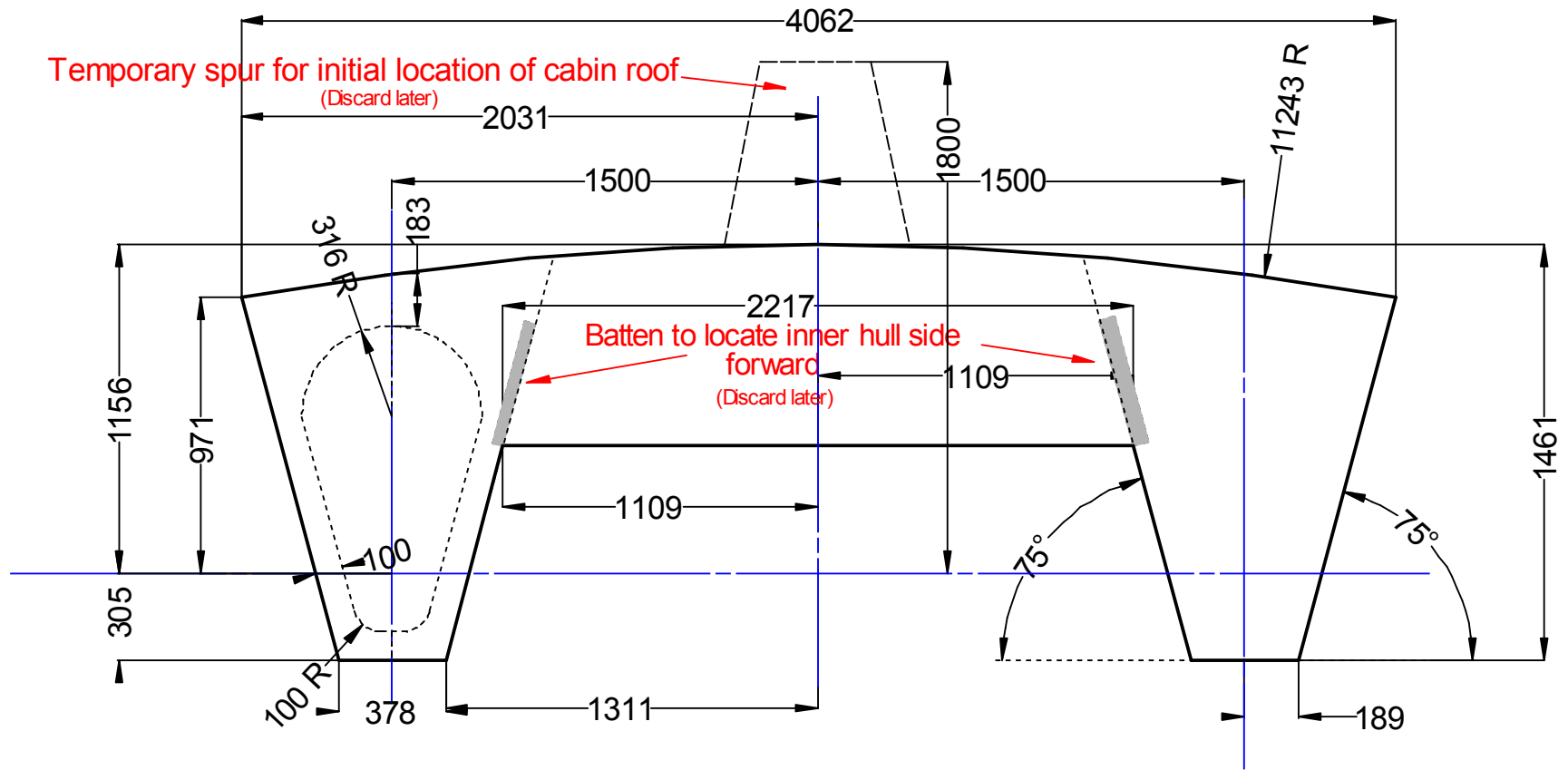

AFT BULKHEAD PANEL

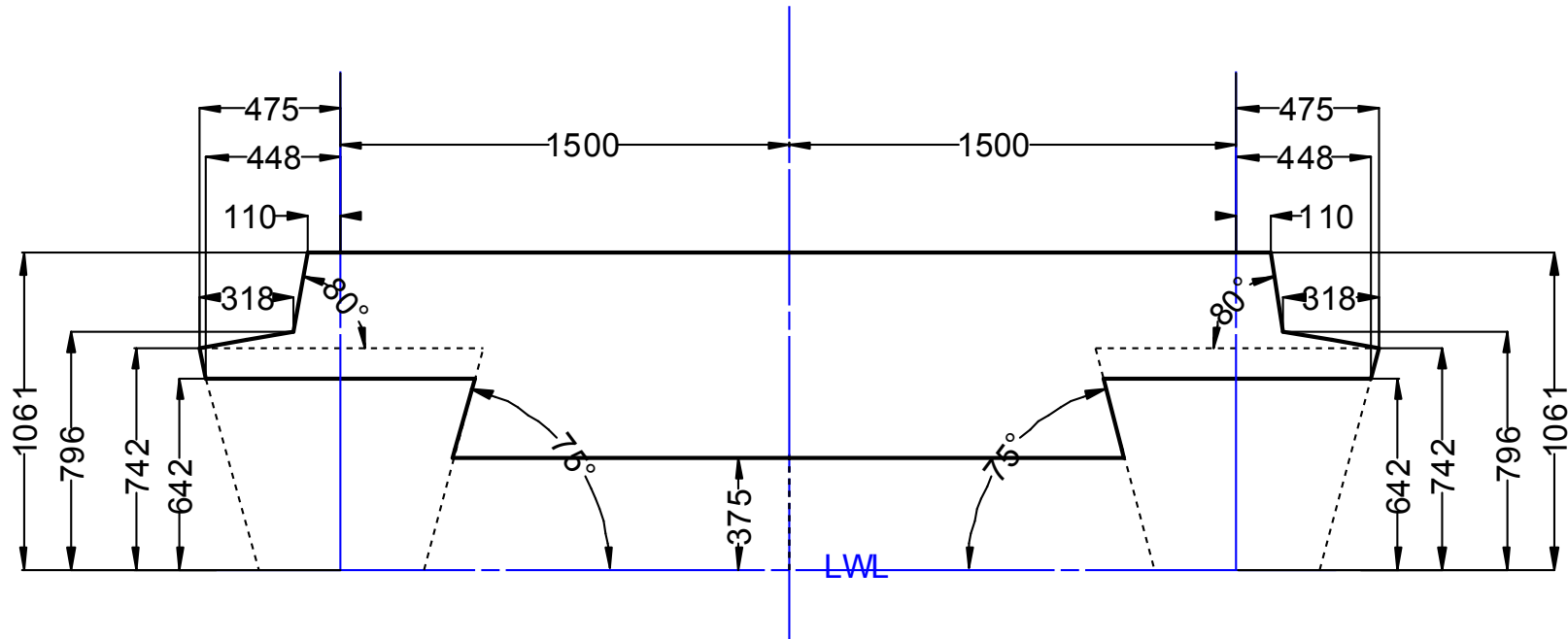

BRIDGEDECK PANELS

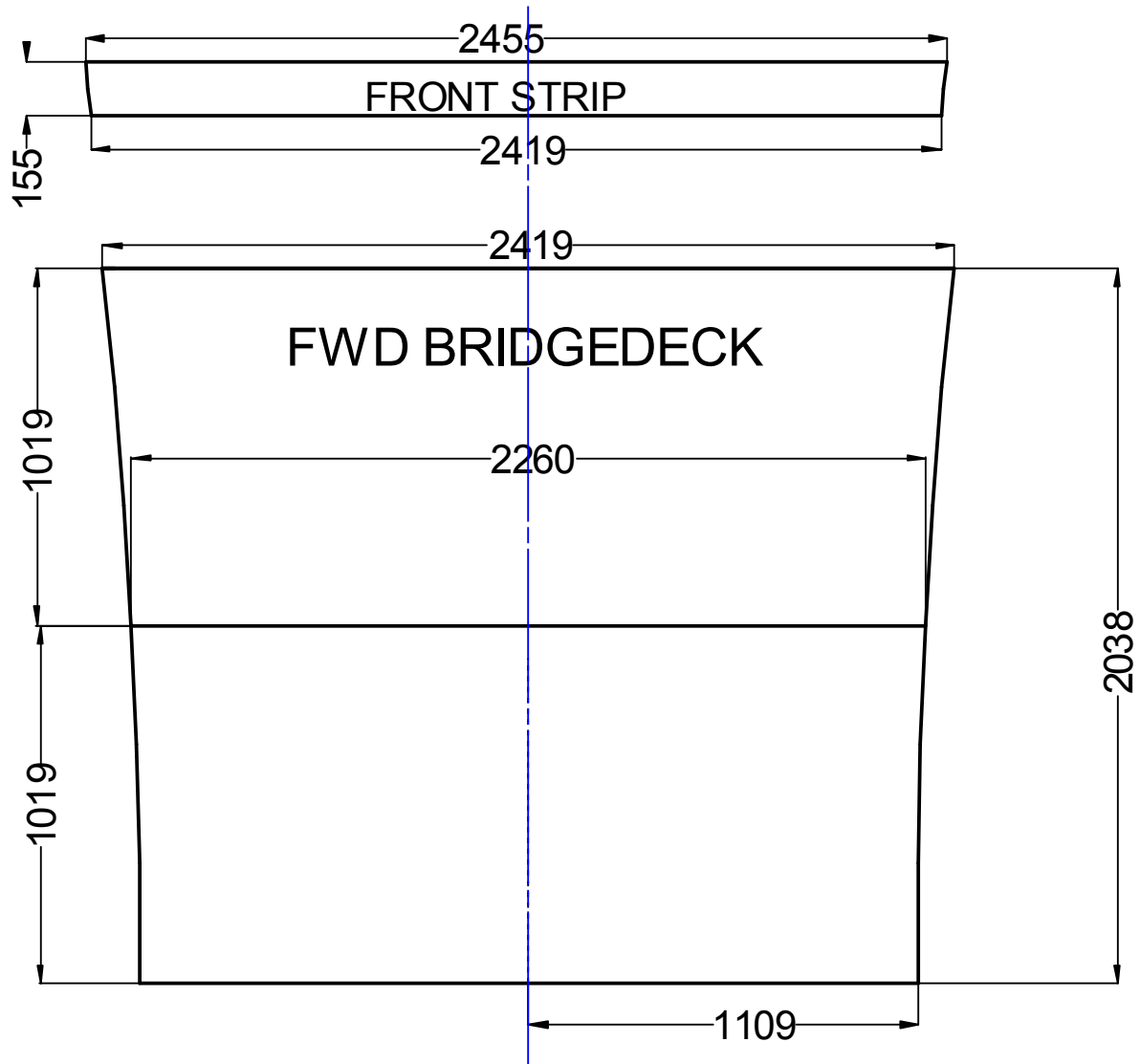

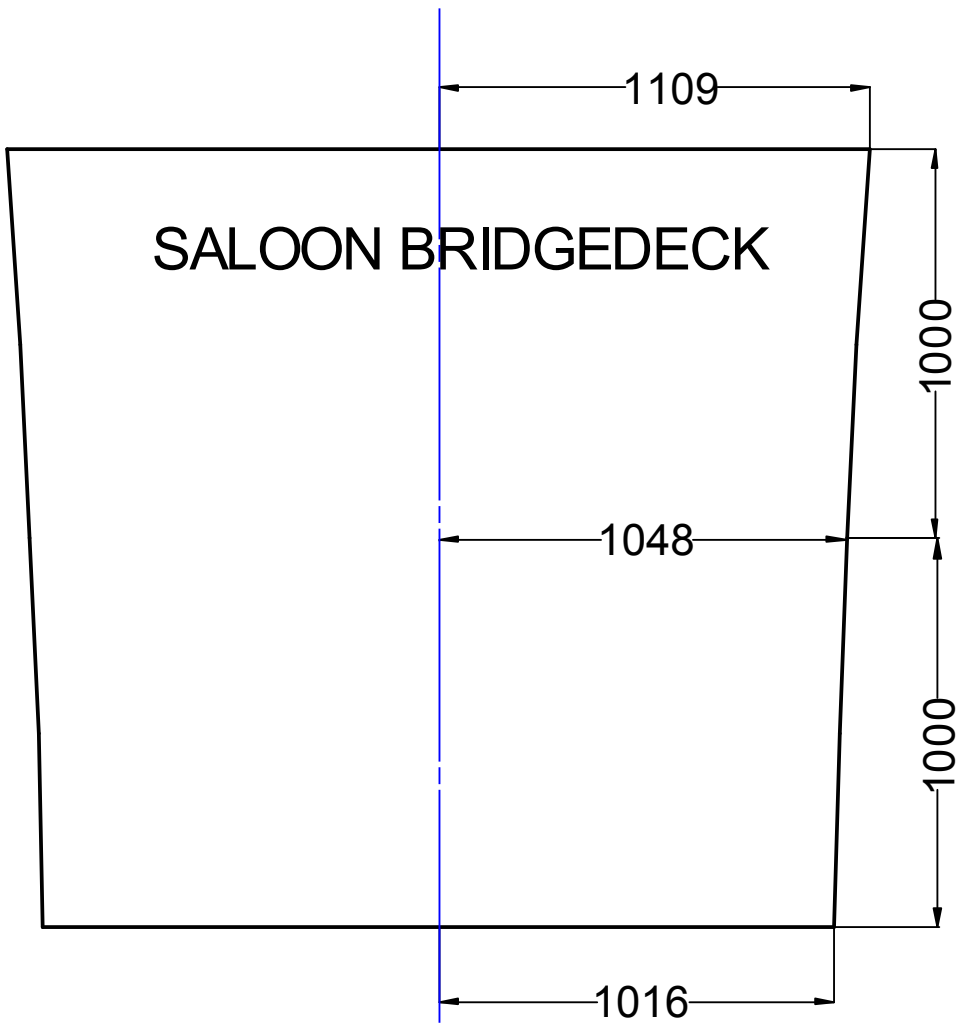

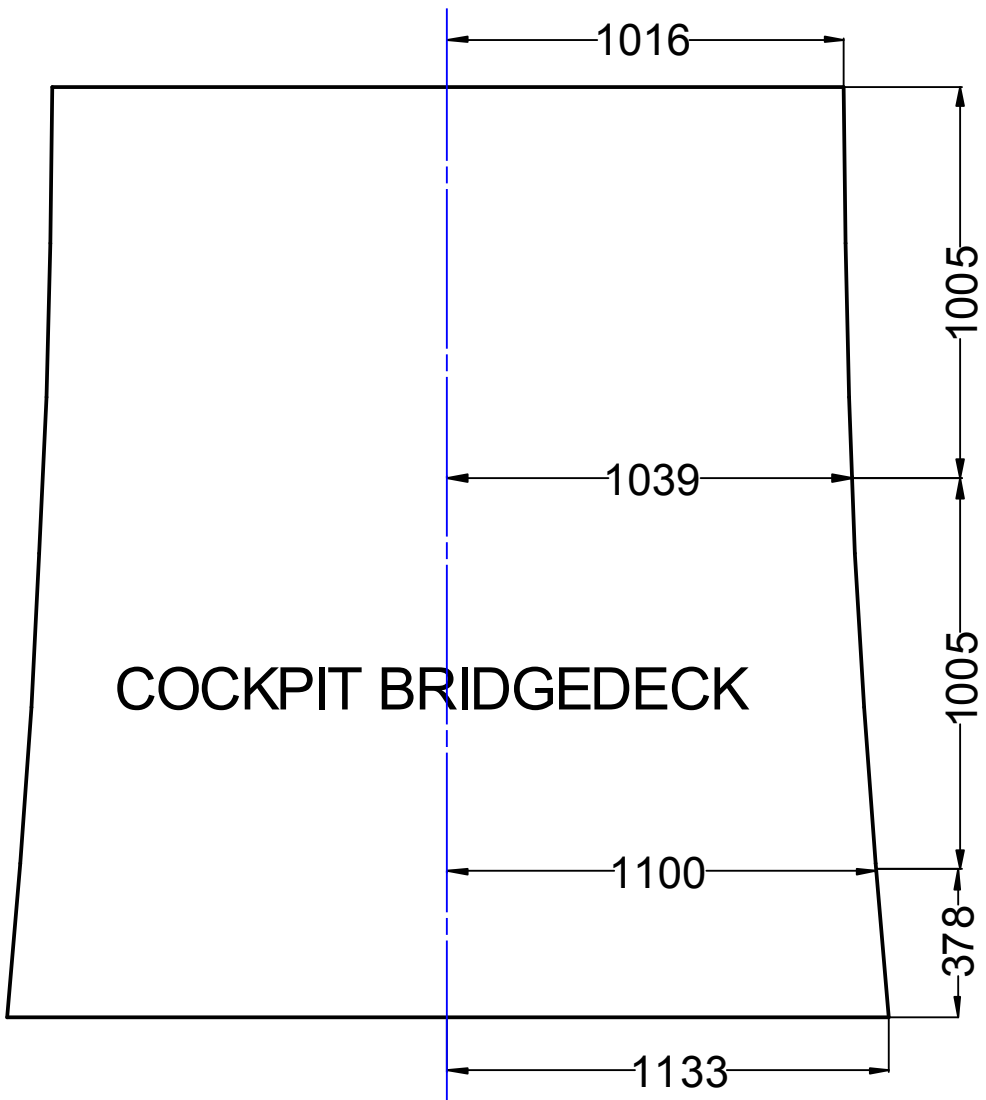

DIVIDER & DECK SUPPORT PANELS

TO GO BETWEEN FORWARD BRIDGEDECK AND FOREDECK ALONG CENTRE
TO GIVE 2 x ANCHOR, CHAIN & WARP LOCKERS

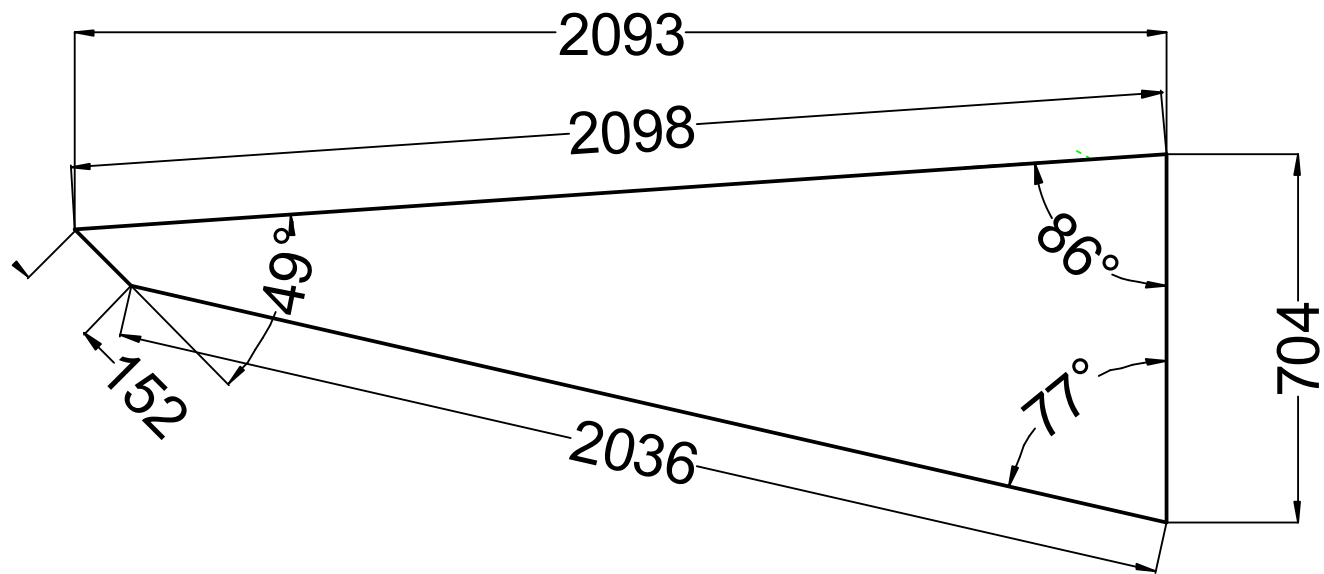

FOREDECK PANEL

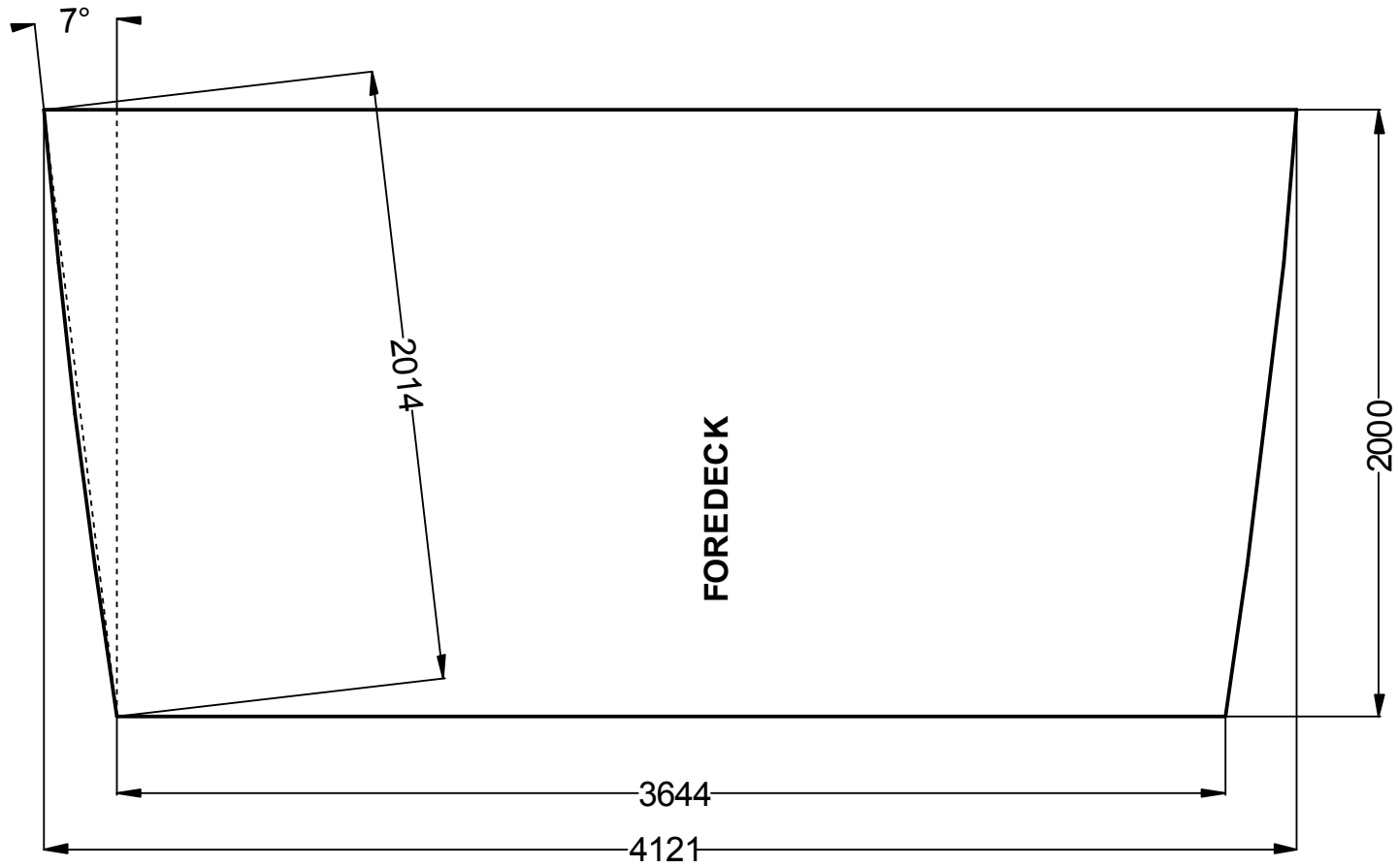

SIDE DECK PANELS

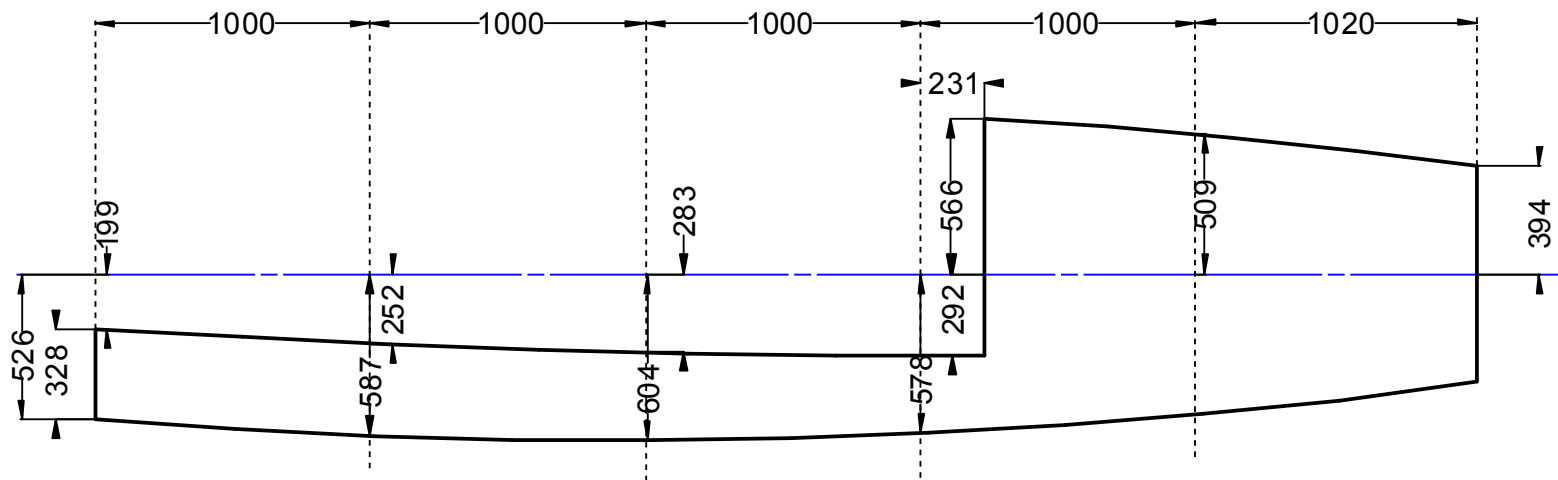
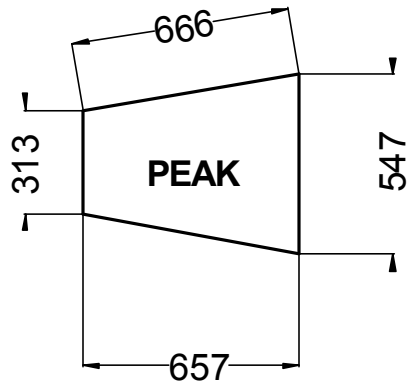

SIDE & AFT DECK (Aft deck covers aft bunk & is cockpit seat.)

SALOON & COCKPIT SIDE PANELS

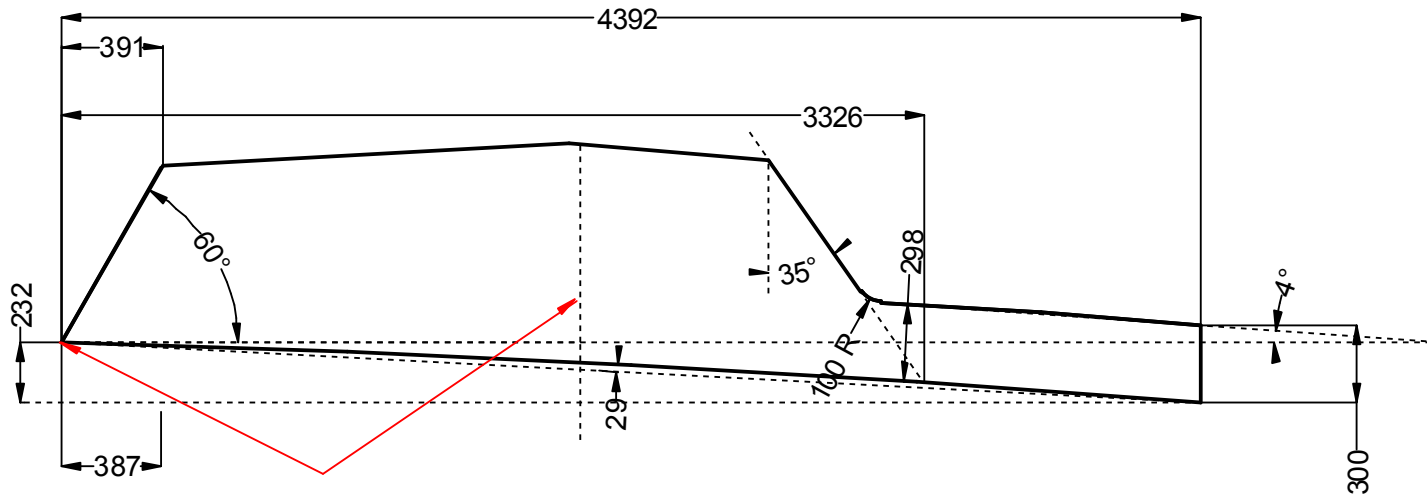

SALOON ROOF PANEL

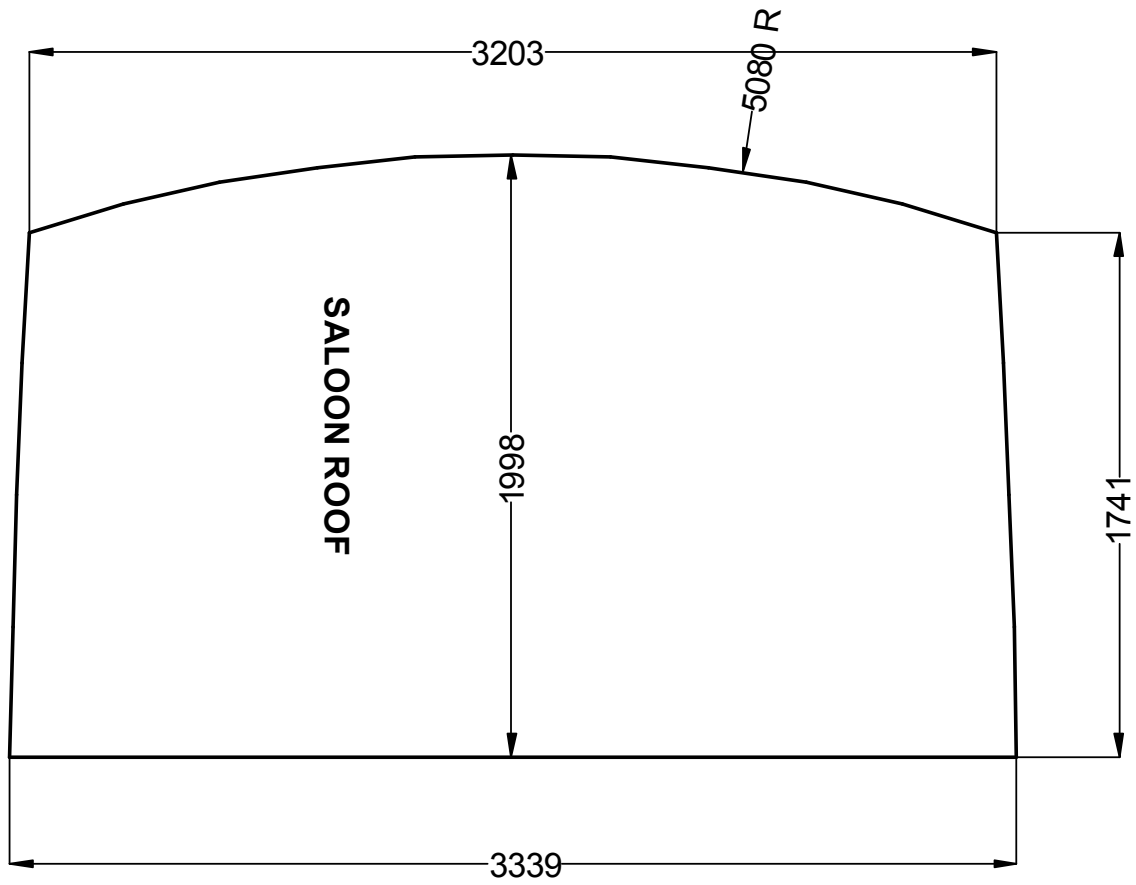

SALOON FRONT PANEL

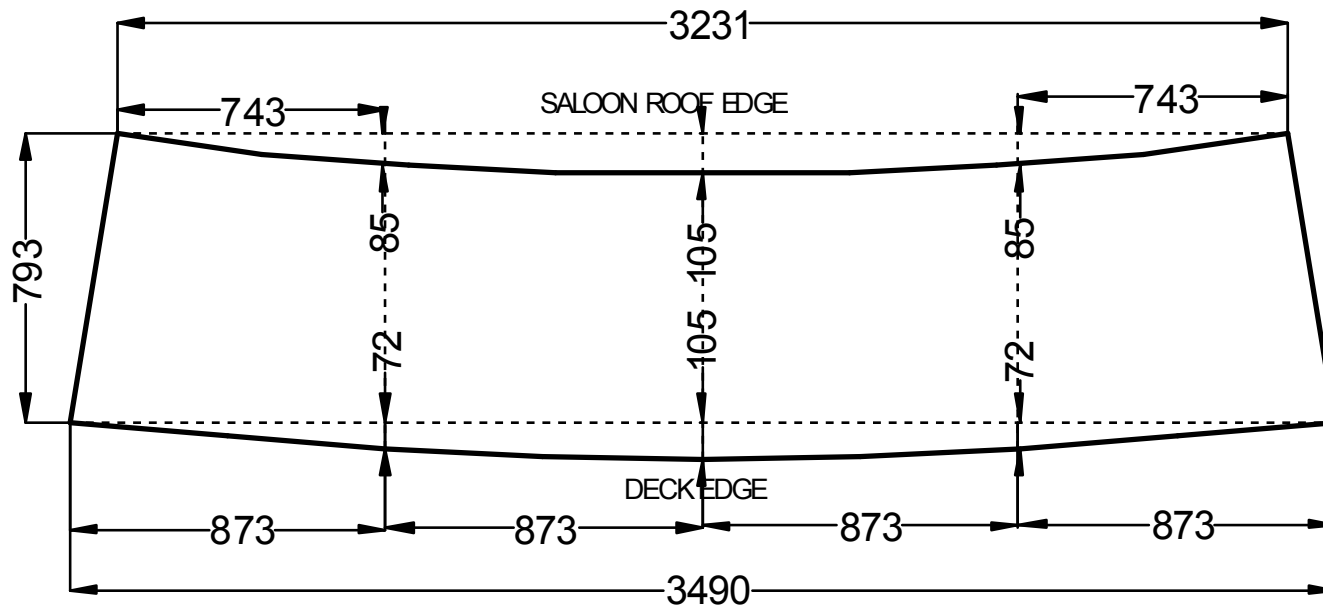

This is a conic projection on which I'm a little rusty. Suggest you try it out in hardboard first, just in case!

Once all the above panels have been assembled, the remaining panels for closing off the aft single cabins and installing cockpit lockers are all simple flats and can be measured off the construction so far.

I don't plan anymore updates unless someone discovers a design error.

BACKGROUND & PHILOSOPHY.

In 1973 I was 36 years old and crewing in a Halcyon 27, a long keeled monohull. We were running in a F5/6 and our skipper was pushing. The foresail was poled out on one side and the mainsail lashed forward on the other. Neither was reefed. We were rolling slowly and rhythmically, water splashing everywhere as the pole and the boom dipped into the sea. I was wedged in a pushpit corner in my oilies and feeling a bit sick when I saw an Iroquois cat overtaking us on the same course. It had up a scrap of mainsail, nothing else. The skipper was standing in his cockpit in a dry shirt. He was handed a hot mug of something from below. A hot mug of anything was out of the question for us. The Iroquois was steady, comfortable, safe and dry - and faster! That was my Toad of Toad Hall moment. Poop! Poop!

Since then I've sailed many cats, built some to order using either plywood/epoxy or GRP foam/balsa sandwich, owned four and worked with or talked at length to some of the pioneering designers and/or builders of my generation and earlier who were ...

Derek Kelsall when he was based in Kent, England,
James Wharram in Cornwall, England,
Chris Hammond at his garden centre (or nursery?) in S England,
Tom and Mary Lack at Christchurch, England,
Peter Spronk when he had a bungalow and a big shed in S England.

I've not met Richard Woods but I admire his designs, he favours lightness and performance. I've seen Kismet Dezines on paper and been impressed, they favour building simplicity and flat bottomed hulls. I've sailed an Iroquois and loved it but thought it too powerful and complex for safe single handing. I've cruised on a Catalac 8m, had fun and was very comfortable but thought it too slow. Hironnelles sail very well and are easy to single handed but are cramped and slam. I've sailed in heavy seas in a Prout Snowgoose and a Heavenly Twins 26 and experienced a lot of slamming.

It is now 2009 and based on my own experiences I have designed the Felix 26, a new small cruising catamaran with a sloop rig. She will sleep 4 adults and cruise at around 7 knots. She will be very simple to build and easy to sail single handed. One person should be able manhandle her when mooring or pushing off. She is a sedate cruiser but with both the speed to escape bad weather or the shape to sail through it if she can't escape.

The program *Hullform 9.1* was used to help develop her hulls. It speeds up the mathematics of designing, giving quick answers to where the various hull centres of your draft designs are located.

Felix won't be everybody's ideal but she is mine.

REDUCING LEEWAY

Catamarans remain too influenced by monohull yacht designs which favour roundish hulls because of heeling. Round hulls have the least wetted area but they're hard to build. In any case monohulls need keels for stability and to reduce leeway and keels increase wetted areas.

Now consider high sided road trucks with square edges at the top. They topple over in strong side winds whereas those with round edges stay upright. It's the drag from vortices along the square edges that pulls them over. Round edges don't produce vortices. For this reason towed caravans with round edges are safer to pull than square edged ones. Square edges in the air are bad.

Conversely square edges in the water can be good. Monohull keels have straight edges creating vortices, adding sideways drag to their lateral resistance. A dory or 'flattie' has a sharp edged hull but if it's a monohull its beam is wide for stability resulting in a shallow draft which lessens the lateral resistance thereby offsetting the extra drag of the flattie shape. In catamarans narrow hulls are a virtue and instability is not a problem, flattie hulls can be deep. In small catamarans this flatness is insignificant when countering pounding. For large cats the chines are rounded at the bows to avoid pounding and at the sterns to improve flow as the water closes behind the hulls.

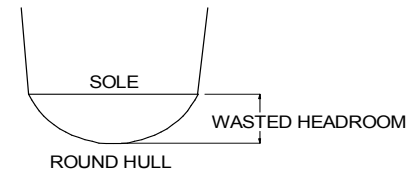
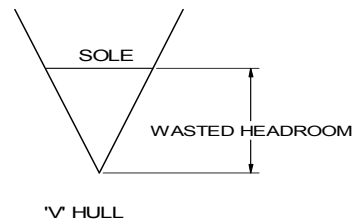

Flatties also provide headroom with much less material and building effort.